

## FEATURES

- Intel Tillamook™ Pentium 166MHz and 266MHz MMX with 32KB of L1 cache and 512KB of onboard pipeline L2 cache
- 32MB or 64MB of system SDRAM
- Socket for up to 288MB bootable DiskOnChip® or BIOS extension EPROM
- Industry standard Award BIOS
- PC-compatible; uses Intel 430TX chip set
- Two RS-232 serial ports each with 16 byte FIFO, optional RS-422/485/J1708 support on both channels
- EPP/ECP compatible printer port (LPT)
- Universal Serial Bus (USB) supported
- Ultra DMA/33 EIDE hard drive controller
- Floppy disk controller supports 1 or 2 drives
- PC/104 and PC/104-Plus expansion connectors
- AT keyboard controller and PS2 mouse support
- Two interrupt controllers and 7 DMA channels
- Three 16-bit counter/timers
- Real time clock, WDT and power fail reset
- On-board CPU power supply
- 8/16-bit STD Bus interface
- Asynchronous bus controller assures compatibility with slower STD Bus I/O cards
- Extended operating temperature available for CMOS STD Bus: -40°C to +85°C
- +5 volt only operation
- Small size: 4.5" x 7.0"

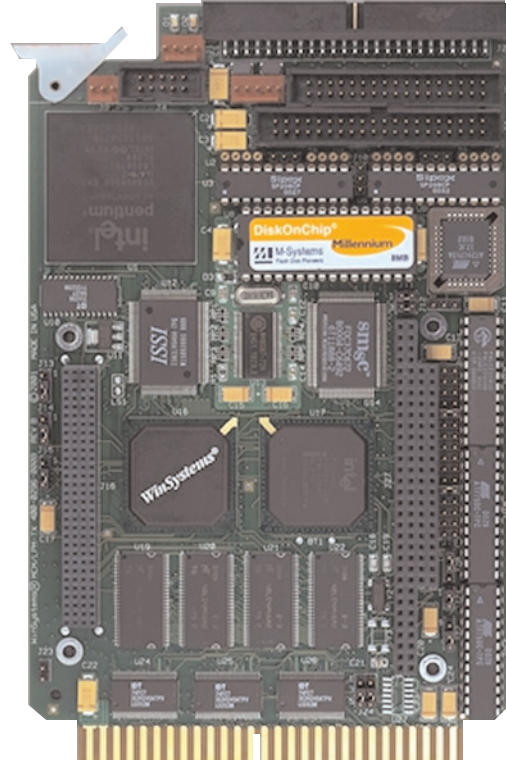

- Upgrade for WinSystems' MCM/LPM-DX5 and replaces Ziotech® and Pro-Log® Pentium CPUs

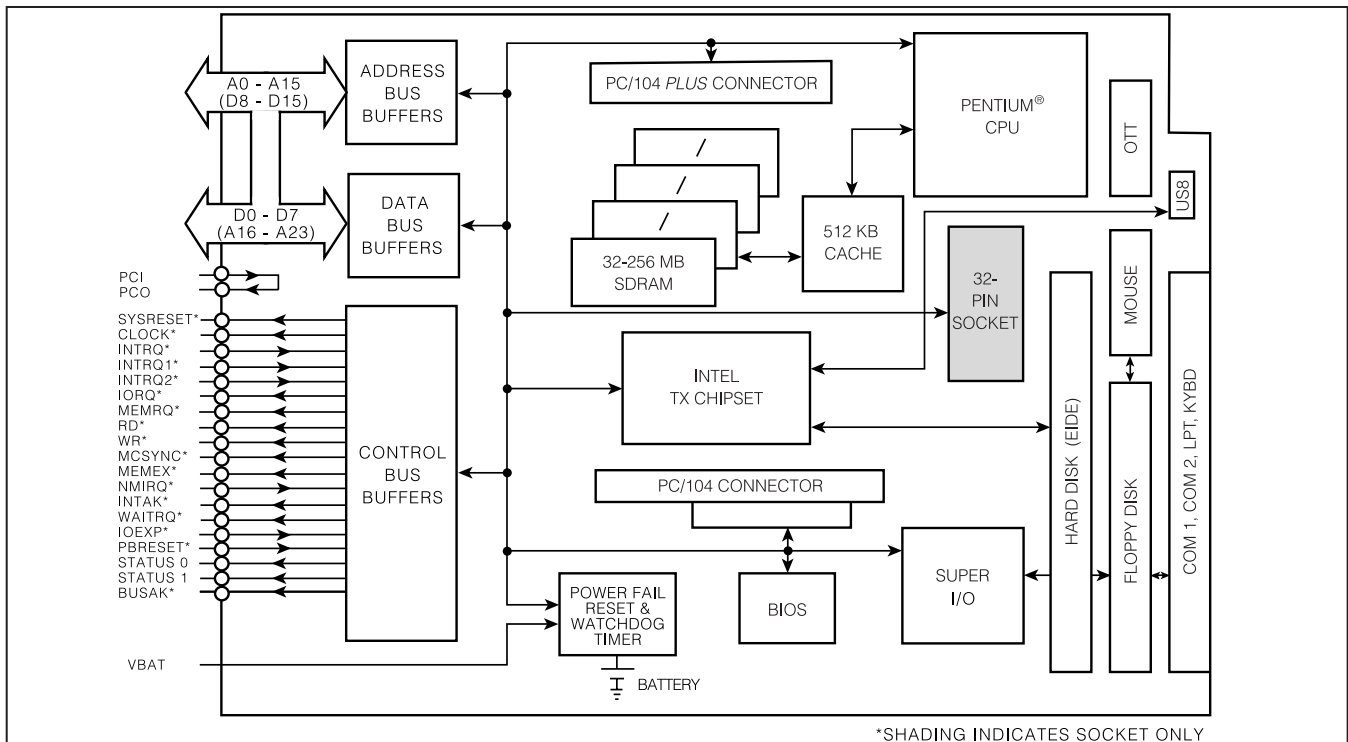

---

## OVERVIEW

---

The MCM-TX is a STD Bus and the LPM-TX is a CMOS STD Bus high-performance, cost-effective, single board computer for computational-demanding applications. It is configured with a 166MHz or 266MHz Pentium CPU, two serial COM channels, and the standard AT peripheral feature set all on a single board. It supports expansion options with the STD Bus, PC/104 or PC/104-Plus bus and USB support for maximum design flexibility and reliability.

The CMOS STD Bus 166MHz board does not require a fan and will operate over an extended temperature range that makes it ideal for rugged applications requiring an STD Bus embedded PC. Its PC software compatibility assures easy program development, and checkout.

This board is designed to be an upgrade for existing WinSystems' CPUs as well as replacing both Ziatech® and Pro-Log® STD Bus cards. Contact WinSystems' applications engineering department for further details.

**CMOS STD Bus** - The MCM prefix on the TX card designates a standard STD Bus board. The LPM prefix designates a CMOS STD Bus board. A MCM/LPM prefix indicates the card has the same features and functionality and is available in both CMOS and regular NMOS/TTL logic. The differences between these two are the power requirements and operational temperature range.

## FUNCTIONAL CAPABILITY

---

**Processor** - The MCM/LPM-TX is built with the low power Intel 166MHz or 266MHz "Tillamook" Pentium processor with 32KB of internal L1 cache. The part is a 362-pin ball grid part that is surface mounted to the board. The Pentium is a 32-bit processor with a 64-bit data bus to improve the data transfer rate. It also includes the MMX technology for increased performance for communications and multimedia applications.

All application software written for the 386 and 486 family of microprocessors will run on the Pentium processor. The pipelined floating-point unit has been completely redesigned over the Intel486. Faster algorithms provide up to a 10X-speed improvement for common operations including add, multiply, and load.

**System Controller** - An Intel 430TX PCI set is the system controller for this SBC. It consists of the 82439TX System Controller (MTXC) and the 82371EB PCI-ISA-IDE Xcelerator (PIIX4E). The MTXC provides an integrated solution for the system controller and data path components for a Pentium processor system. It has the 64-bit

Host and SDRAM Bus interface, 32-bit/33MHz PCI Bus interface, L2 cache controller, and it integrates the PCI arbiter. The MTXC also implements extensive power management features. The MTXC works with the PIIX4E to provide the PCI-to-ISA/IDE bridge functions along with other features such as a fast IDE interface (PIO mode 4 and Ultra DMA/33), Plug-n-Play (PnP) port, and USB controller functions. It also provides the core logic that makes the board PC/AT software compatible including integrated peripheral controllers (two 82C37 DMAs, 82C54 timer, two 82C59 PICs, RTC, and CMOS memory) and the ISA bus for support of STD Bus and PC/104 expansion.

**Memory** - The chipset implements a 66MHz front side bus. The board is populated with 32MB or 64MB of Synchronous Dynamic RAM (SDRAM). The parts are soldered directly onto the board to improve reliability for applications subject to shock and vibration.

The MCM/LPM-TX is shipped with 512KB of onboard pipelined burst L2 cache to improve the performance of the system. A 64K x 64 SRAM is the cache device that is direct mapped in Write Back mode only.

**BIOS** - An industry-standard, Award BIOS is on the board to provide configuration flexibility, performance and AT-compatibility. It is set with a factory default that can be modified by the user. The BIOS is located in an EEPROM that can be modified without removing the storage device from the board. It will support diskless, keyboardless, and videoless operation as well as BIOS shadowing.

Also BIOS extensions can be programmed into another EPROM for remote boot from the Ethernet, video extensions, etc. This socket is shared with the SSD.

**Direct Memory Access (DMA)** - Seven DMA channels are supported with Channel 2 dedicated to the floppy disk controller. The LPT is jumper selectable for ECP operation. The other DMA channels are wired to the PC/104 connector.

**Floppy Disk Support** - Up to two 3.5" or 5.25" drives from 360KB through 1.44MB formats are supported by the floppy disk controller. It has an enhanced advanced digital data separator for different data rates, programmable pre-compensation rates, plus underflow and overflow protection. Open drain, push-pull drivers are wired to a single 34-pin connector on 0.100-inch centers. Both drives can be daisy chained from a single cable.

**EIDE Hard Disk Interface** - The MCM/LPM-TX incorporates a PCI EIDE local bus interface for independent timing of up to 2 drives. PIO Mode 4 and Bus Master IDE

---

transfers of up to 14 Mbytes/sec are supported. Also, it supports Ultra DMA/33 synchronous DMA mode transfers up to 33 Mbytes/sec. The EIDE controller interface channel is wired to a 40-pin header connector on 0.100-inch centers. A red activity LED blinks during data transfer to provide visual status information.

**Solid State Disk (SSD) Support** - A JEDEC-standard 32-pin, machine-tooled socket is provided to accept an M-Systems' DiskOnChip® (DOC). The DOC is available in storage capacities from 8 to 288Mbyte in a single device. It includes an internal Flash file system that provides hard disk read/write compatibility, automatic bad block management, and wear-leveling.

**USB** -The Universal Serial Bus (USB) offers users simple connectivity with peripheral devices. This board has a USB port that supports transfers at either 1.5 or 12 Mbits/sec. The USB is wired to a 4-pin connector. An optional CBL-249-1 is the interface cable adapter to the standard female USB connector.

**Serial Communications** -Two independent, full-duplex, serial asynchronous channels are onboard. Both the send and receive registers of each channel has a 16-byte FIFO. This device is a dual 16C550 compatible UART that offers software compatibility with PC-type driver programs.

Independent control of transmit, receive, line status and data set interrupts are on all channels. Each channel is setup to provide internal diagnostics such as loopback and echo mode on the data stream. An independent on-chip software programmable baud rate generator is selectable from 50 through 115.2 kbits/sec. Individual modem handshake control signals are supported for all channels.

RS-232 interface levels are supported on all channels. The RS-232 drivers have an on-chip charge pump to generate the plus and minus voltages so that the MCM/LPM-TX only requires +5 volts to operate.

Also RS-422, RS-485 or J1708 electrical levels can be supported on COM1 and COM2 by removing the RS-232 transceivers and installing the optional CK-75176 chip kit per channel.

All serial channels are configured as Data Terminal Equipment (DTE). COM1 and COM2 are wired to a 50-pin, multi-I/O connector at the edge of the board. WinSystems offers the optional CBL-247-1 that adapts each serial channel to 9-pin male "D" connectors

**Line Printer Port** -The MCM/LPM-TX has a parallel port that may be operated in standard and bidirectional as

well as Extended Capabilities Port (ECP - IEEE-1284) and Enhanced Parallel Port (EPP) modes. The controller chip is designed to provide enhanced ESD and latch-up protection of up to 4KV/300mA.

The printer port can also be used as two additional general-purpose I/O ports if a printer is not required. The first port is configured as 8 input or output only lines. The other I/O port is configured as 5 input and 3 output lines.

**Keyboard/Mouse Controller** - An 80C42 equivalent controller supports a PC/AT-compatible keyboard. It is wired to the 50-pin multi-I/O connector. The CBL-247-1 adapter cable provides the mate to a PS-2 type keyboard.

A mouse controller is on board. Its input is accessible through a 5-pin connector. WinSystems offers an optional CBL-225-1 adapter cable that interfaces the PS/2 mouse cable to this board.

**Interrupt Sources** - Two 82C59A compatible interrupt controllers accept inputs from the onboard peripherals, the INTRQ\* lines from the STD Bus, and the PC/104 Bus interrupt sources. Also four PCI interrupt sources are supported on the PC/104-Plus Bus which are PnP compliant.

The MCM/LPM-TX contains a 10-pin interrupt connector at the top of the card (OTT). This provides backward compatibility for WinSystems' MCM/LPM-286, MCM/LPM-386SX, MCM/LPM-486SLC, and MCM/LPM-DX5 boards. It also provides five additional interrupt sources to the board in addition to those provided through the STD Bus backplane.

**I/O** -The MCM/LPM-TX conforms to the PC-AT I/O map and STD Bus standard 10-bit addressing. It will support older STD Bus I/O boards that decode only 8 address bits, 8 bits with IOEXP\*, and the newer 10-bit cards.

**Status LED** -A green status LED is also available to monitor system activity. Under a user's program control, it can indicate error conditions or blink different patterns to provide a visual indication of system status.

**Real Time Clock** - An MC146818A-compatible clock supports a number of features including periodic and alarm interrupt capabilities. In addition to the time and date keeping functions, the system configuration is kept in CMOS RAM contained within the clock section.

**Watchdog Timer** - A software/hardware enabled, re-triggerable watchdog timer is provided. This timer must

be updated at least once every 1.5 seconds otherwise a failure is assumed and the board will be reset. This circuit is important for use in remote and unattended applications.

**Timers** - Three, independent 82C54 compatible 16-bit timers are supported. Channel 0 is wired to interrupt Channel 0, Channel 1 generates the DRAM refresh using DMA Channel 0, and the speaker port uses Channel 2.

**Speaker** - An onboard piezo transducer is available for sound generation. A beep code is generated that corresponds to any BIOS error codes (if required) during the power up or reset sequence.

**Reset** - A precision voltage monitors the +5 volt status. Upon detection of an out-of-tolerance condition, the board is reset. This action is critically important in order to detect brownout or power fail conditions. The reset circuit also ensures that the power is nominal before executing a power-on reset.

**Battery** - A 350 mA battery supplies the MCM/LPM-TX board with standby power for the real time clock and CMOS setup RAM. A power supervisory circuit senses the off-board voltage and automatically switches to internal power when it drops below normal.

**Expansion Options** - The MCM/LPM-TX provides a common computer core from which engineers can add user designed or off-the-shelf boards to match their exact configuration. The board can support 3 different modes: STD Bus, PC/104 bus and PC/104-Plus bus.

**STD Bus** - This board supports both 8- and 16-bit transfers on the STD Bus. Logic automatically detects the memory and I/O transfer data path widths and aligns the transfers accordingly.

As the approved IEEE-961 standard, the STD Bus is popular worldwide. It provides a simple-to-use I/O bus in a small card size (4.5 x 6.5-inches). The cards mount securely in card cages that can tolerate shock and vibration which makes them ideal for rugged industrial applications.

**STD Bus Card Cages & Backplanes** - WinSystems has a wide selection of backplanes, assembled card cages, and powered racks. These units are designed to provide the highest integrity and reliability needed as a foundation for an embedded system.

The backplanes and card cages work with STD Bus processors from the original Z80 to the newest Pentium CPUs. They are designed to minimize noise and crosstalk while maintaining good power distribution,

massive ground planes and a constant characteristic impedance on the signal lines.

Three mounting configurations are available for card cages: rack mount, table mount, or wall mount. Board spacing is available in either 0.625 or 0.75-inches. From 2 to 26 slots are available. All offer a vertical card orientation to take advantage of convection cooling. They are constructed of aluminum for lightweight and strength.

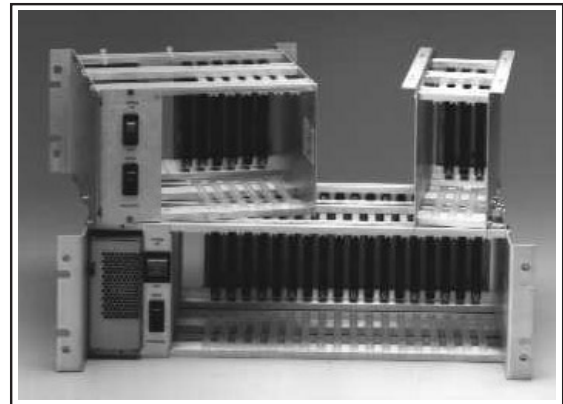

STD Bus Card Cages

WinSystems also offers card cages with 50W or 100W power supplies. These are triple output, high-efficiency supplies that mount inside the card cage. They are universal input switchers that accept a range of 110 to 220VAC. An ON/OFF switch and momentary Reset switch are mounted on a panel for operator convenience.

Multiple backplanes and other options can be installed in a card cage to allow more than one system to occupy a single container. To configure and price a custom backplane or card cage, contact the factory applications engineer with your specification.

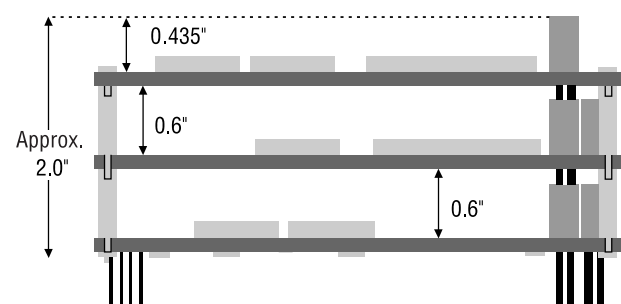

Typical PC/104 and PC/104-Plus Module Stack

**PC/104 and PC104-Plus Bus** - The MCM/LPM-TX supports both the 16-bit PC/104 and a 32-bit PC/104-Plus interface with a connector for each. PC/104 is the ISA

bus and PC/104-Plus is the PCI bus for I/O functions requiring higher data transfer speeds.

PC/104 and PC/104-Plus modules are self-stacking and plug together in a "piggy back" configuration to serve as a mezzanine expansion bus. PC/104 modules are very compact, measuring only 3.6 x 3.8 inches, and are offered by WinSystems and a number of third party companies worldwide. Module functions include specialty serial I/O, digital I/O, 10/100 Ethernet, GPS, modem, audio, SCSI, etc.

For more information and a specification on the PC/104 and PC/104-Plus Bus, refer to WinSystems' Volume 2 or Volume 3 Data Book or write the PC/104 Consortium.

**Multi-I/O Connector** - WinSystems offers the optional CBL-247-1, Multi-I/O cable adapter for the COM1, COM2, LPT1 and keyboard. These four ports are combined into one 50-pin header at the edge of the board. The CBL-247-1 is a 1-foot adapter cable that offers a more convenient termination. COM1 and COM2 are 9-pin male "D" connectors with strain relief. LPT1 is a 25-pin "D" female socket with strain relief. The keyboard is a standard 5-pin PS/2 connector socket.



Drawing of CBL-247-1

## SOFTWARE SUPPORT

**Software** - The MCM/LPM-TX is designed to run both 16-bit and 32-bit x86 instruction set software. It is compatible with Microsoft's Windows operating systems, such as Windows CE, Windows 98, and Windows NT®, and Windows NTE as well as the applications that run on them. It also supports Linux and other PC-compatible x86 operating systems such as QNX, and VxWorks. It will also run other real-time executives that require a "PC-AT" hardware environment.

**Software Developers Kit** - WinSystems offers the SDK2-STD-CX15-D software developers kit to supply the necessary hardware, software and cables to begin program development with a STD Bus system.

One of the configurations consists of DOS 7.x, CBL-247-1 Multi-I/O cable, CD-ROM drive, a 2GB or larger hard

disk plus controller cable, a 1.44 MB high density 3.5" floppy disk plus controller cable and triple output power supply housed in an enclosure. A 15-slot, STD Bus card cage is mounted on top of the enclosure.



SDK2-STD-CX15-D Software Developers Kit

The power supply is a 80-Watt universal switcher that will accept input voltages from 85VAC to 264VAC. Output voltages are +5 volts at 12A, +12 volts at 3A, and -12 volts at 1.0A. The power supply, floppy disk and hard disk are mounted in a black anodized enclosure. The packaging permits easy access to the board, PC/104 modules and peripherals during program development.

## SPECIFICATIONS

### Electrical

- CPU Clock: 166 or 266 MHz
- PC/104 Interface: 16-bit, non-stackthrough
- PC/104-Plus Interface: 32-bit PCI, non-stackthrough
- Serial Interface: 2 Serial channels with RS-232 levels RS-422/485/J1708 optional using the CK-75176 chip kit
- LPT Interface: Bidirectional LPT with ECP/EPP
- EIDE interface: Supports 2 drives
- Floppy Disk Interface: BIOS supports one or two 360K/720K/1.2M/1.44M drives

Vcc = +5V ±5% at 1.5A: MCM-TX-166-32M

Vcc = +5V ±5% at 1.9A: MCM-TX-266-32M

### System Memory

- Addressing: 256 Megabytes
- Capacity: 32MB or 64MB SDRAM
- L2 Cache: 512K bytes

---

### Solid State Disk

Capacity: One, 32-pin memory sockets supports up to a 288MB DOC<sup>®</sup>

### Mechanical

Dimensions: 4.5" x 7.0"  
Jumpers: 0.025" square posts

### Connectors

Serial, Parallel, Keyboard: 50-pin on 0.100" grid  
Floppy Disk Interface: 34-pin on 0.100" grid  
EIDE Interface: 40-pin on 0.100" grid  
USB interface: 5-pin on 0.100" grid  
OTT Interrupts: 10-pin on 0.100" grid  
PC/104 Bus: 64-pin 0.100" socket  
40-pin 0.100" socket  
PC/104-Plus Bus: 120-pin, 2mm (4x30) socket  
STD Bus: 56-pin 0.125" card edge

### Environmental

Operating Temperature: 166MHz: -40°C to +85°C  
266MHz: -40°C to +70°C  
Non-condensing relative humidity: 5% to 95%

### CMOS STD Bus

LPM-TX-166-32M CMOS STD Bus 166MHz Pentium SBC with 32MB SDRAM  
LPM-TX-166-64M CMOS SBC with 64MB

ADP-SPEAKER Optional Powered Speaker  
CBL-225-1 PS/2 mouse adapter cable  
CBL-247-1 1 ft., Multi-I/O adapter cable  
CBL-249-1 Universal Serial Bus Interface cable  
CK-75176-2 RS-422/485 chip kit  
PCM-CFlash-2 PC/104 compact pFlash card  
PCM-IDEFLASH IDE Flash module  
FLASH-MD2000-DXX DiskOnChip<sup>®</sup>; where XX = 8, 16, 32, 48, 72, 144, or 288MB  
SDK2-STD-CX15-D Software Developers Kit

WinSystems reserves the right to make changes to products and/or documentation without further notification.

## ORDERING INFORMATION

---

### STD Bus

MCM-TX-166-32M STD Bus 166MHz Pentium SBC with 32MB of SDRAM  
MCM-TX166-64M 166 MHz STD SBC with 64MB  
MCM-TX-266-32M STD Bus 266MHz Pentium SBC with 32MB of SDRAM  
MCM-TX-266-64M 266 MHz STD SBC with 64MB

