

FEATURES

- 16 single ended/8 differential input channels
- 12-bit resolution
- User configurable gains of 1 to 1000
- Throughput to 13,333 channels per second
- Interrupt on conversion complete
- Processor independent including 80186, 8088, HD64180, 68008, Z80, and 8085A
- +5V Operation with optional DC/DC converter
- Jumper selectable I/O addressing
- Replacement for Analog Devices RTI-1260
- Optional CMOS version: LPM-A/D12 and LPM-1280

The MCM-A/D12 and MCM-1260 cards provide 8 differential or 16 single-ended 12-bit analog input channels with a throughput of up to 13,333 channels per second. User programmable gains from 1 to 1000 allow effective input ranges from 10 millivolts to 10 volts. Installation of an optional DC/DC converter makes the board require +5 volts only.

FUNCTIONAL CAPABILITY

Bus Interface - Full data, address, and control line buffering is provided to and from the bus. It supports all STD Bus processors operating with up to a 8 MHz system clock without wait states.

Addressing - The card is configured for 8-bit I/O

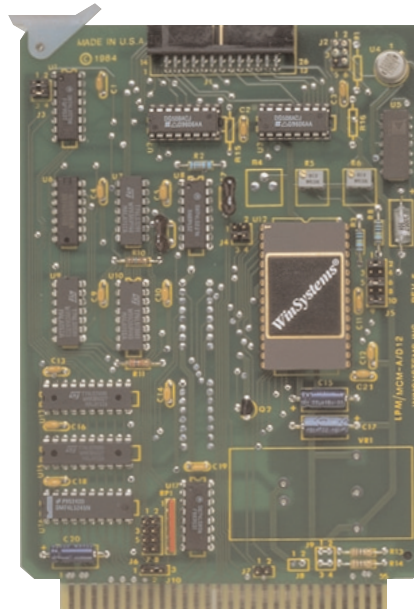

addressing. A total of 4 contiguous addresses are required and it is jumper selectable.

Analog Input Section - The card contains a multiplexer, a pin programmable gain instrumentation amplifier, and a sample-hold circuit. The card accepts up to

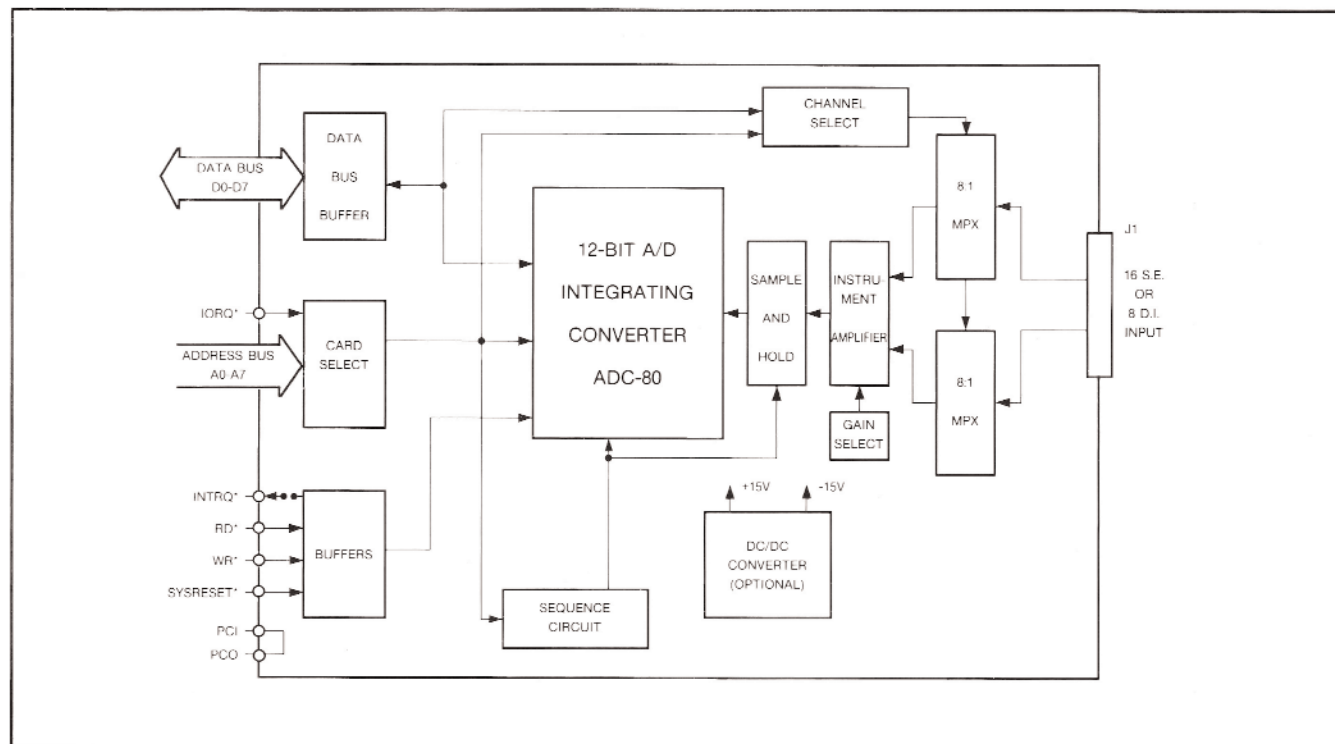

either 16 single-ended or 8 differential inputs. The multiplexer switches' can withstand $\pm 20V$ with the power off, and $\pm 32V$ with the power on. The outputs of the multiplexers are connected to an instrumentation amplifier which is jumper selectable for gains of 1, 10, 100, and 500. Binding posts for an external user selectable resistor allows the user to select a fifth programmable gain from 1 to 1000. The output of the amplifier is connected to a sample-hold circuit which "freezes" the analog input voltage while the A/D converter is performing a conversion. This prevents the voltage from changing while the conversion is in progress.

Analog to Digital Converter - The card contains an Analog Devices ADC-80, 12-bit A/D converter. Coding can be straight binary, offset binary or 2's complement. The input ranges are 0 to +10 VDC and ± 10 VDC.

Input Configuration - Each input channel is wired to a pin and socket and header connector, J1. Flat ribbon cables or discreet wires can be connected to it.

Two different 12-bit A/D boards are available from WinSystems: MCM-A/D12 and MCM-1260. Both cards are functionally and software compatible with the exception of the pin-out on the analog input connector. The MCM-A/D12 uses the WinSystems standard analog signal pin-out and a 26-pin connector. The MCM-1260 uses a 50-pin connector and is compatible with the Analog Devices RTI-1260 board. It permits direct connection with the AC1585-1 screw terminal panel and the 3-B series analog signal conditioning backplanes.

Interrupts - Conversion is begun each time the channel number is written to the board. An end of conversion signal can generate a jumper selectable INTRQ* signal on the STD Bus. Also the signal sets a BUSY flag for use in a polled mode.

DC/DC Power Supply - The card can be operated from ± 12 VDC or ± 15 VDC supplied from the STD Bus. For ± 12 VDC operation, the input voltage range is limited to ± 5 VDC. Other input voltage ranges can be accommodated by installing a single resistor to increase the gain of the instrumentation amplifier.

The MCM-A/D12 and MCM-1260 cards are offered with an optional DC/DC power supply installed and designated as the MCM-A/D12-DC and MCM-1260-DC. This allows the board to operate directly from the microcomputer's +5 volt supply. The DC/DC supply outputs ± 15 for the analog circuitry. If the analog

supply voltages are present in the system, then the extra cost of the optional DC/DC supply is not required.

SPECIFICATIONS

Electrical

Number of Channels: 16 single-ended or 8 differential
Input Impedance: Greater than 100 Megohms
Input Overvoltage: $\pm 20V$
Input Ranges: ± 2.5 V, ± 5 V, 0 to +5 V, 0 to +10V, and $\pm 10V$,
Coding: Straight binary (unipolar)
Offset binary, 2's complement (bipolar)
Resolution: 12-bits
Nonlinearity: $\pm \frac{1}{2}$ LSB
Gain Error: Adjustable to zero
Offset or Zero Error: Adjustable to zero
Conversion Time: 75 microseconds
Power Requirements: Without DC to DC Converter
+5 VDC $\pm 5\%$ @ 300 mA
+12/15 VDC $\pm 5\%$ @ 20 mA
-12/15 VDC $\pm 5\%$ @ 15 mA
With DC to DC Converter
+5 VDC $\pm 5\%$ @ 500 mA

Mechanical

Dimensions: 6.5 x 4.5 inches

Connectors

STD Bus: 56-pin dual 0.125 inch centers
Input: 26-pin dual on 0.100" grid (MCM-A/D12)
50-pin dual on 0.100" grid (MCM-1260)
Jumpers: 0.025" square posts

Environmental

Operating Temperature: 0°C to +65°C
Non-condensing relative humidity: 5% to 95%

ORDERING INFORMATION

MCM A/D12 12-bit analog input board
MCM-A/D12-DC 12-bit analog input board with DC/DC converter for +5 VDC operation
MCM-1260 12-bit analog input board compatible with RTI-1260
MCM-1260-DC 12-bit analog input board with DC to DC converter for single +5 VDC operation compatible with RTI-1260

