

FEATURES

- PC/104 Bus 50W DC/DC power supply
- Wide input voltage range from +6 to +40 Volts
- 5KVA transorb transient suppression on input
- Quick disconnect connector for input voltage
- Output voltages: +5V @ 10A, +12V @ 2A
- High efficiency switching regulator design
- +5V and +12V output wired to PC/104 connector
- Low output ripple
- All outputs short circuit protected
- Load dump transient protection
- Voltage status LEDs
- Small size: 3.6" x 3.8" (90mm x 96mm)
- Operating temperature: -40°C to +85°C
- RoHS compliant

The PCM-HE104-G is a high efficiency, dual output, high-performance DC/DC power supply for PC/104 systems. It is designed for battery or unregulated input applications and is specifically designed for vehicular applications with high transient voltage spikes. It will operate over the full industrial temperature range of -40° to +85° Centigrade.

FUNCTIONAL CAPABILITY

The PCM-HE104-G is a high efficiency, 75KHz switching DC/DC power supply that uses a MOSFET based design to provide outstanding line and load regulation with efficiencies up to 95 percent. Organic Semiconductor (OS-CON) Capacitors provides filtering, which reduces ripple noise below 20mV. OS-CON capacitors have very low ESR values and they will not degrade in operation at extended low temperatures compared to conventional electrolytics. Also, OS-CON capacitors have much longer life (over 6X) at elevated temperatures compared to a standard electrolytic capacitor.

This power supply is especially suited for use in automotive and transportation applications that experience a phenomenon called "load dump". Load dump is an energy surge resulting from disconnecting the battery while being charged. The alternator, with a finite response time from 40mS to 400mS, generates power with nowhere to go which creates an energy surge. The resultant overvoltage transient which is created can exceed 100V (depending on alternator speed and the level of alternator field excitation). Load dumps occur infrequently in a vehicle's lifetime, but any electronics that needs to survive in this environment must be designed for this possibility. The PCM-HE104-G has special circuitry to prevent the load dump transient from harming it or other boards in a PC/104 stack.



Input Voltage - Input power is connected to an onboard, 2-pin, pluggable block connector. Its mate, which accepts up to 14-AWG wire, is included with the PCM-HE104-G. The input voltage range is from 6VDC to 40VDC.

Output Voltage - The PCM-HE104-G is a dual output supply with up to 10A available on the +5 volt output and up to 2A on the +12 volt output for a total of 50W. The +5V output is used to generate the +12V supply. Therefore, if +12V is used, then the amount of current available from the +5V supply will be decreased proportionally. Refer to the technical manual for the calculation.

The PCM-HE104-G is a well designed, stable unit across the entire temperature range. The load regulation measured on the +5V output is less than 60mV and the line regulation is $\pm 40\text{mV}$. The output temperature drift is less than 40 mV and output ripple less than 20mV. There is no minimum current load requirement for either +5V or +12V outputs to keep the supply in regulation.

Terminal Block - Output power is available for non-PC/104 use via connector CN2 located on the edge of the board. Common, +5VDC, and +12VDC are available at the terminal block. It is rated for wires with a cross section of 0.14 - 1.5mm² solid or 0.14 - 1.0mm² fine stranded. This corresponds to 30 - 16-AWG wire.

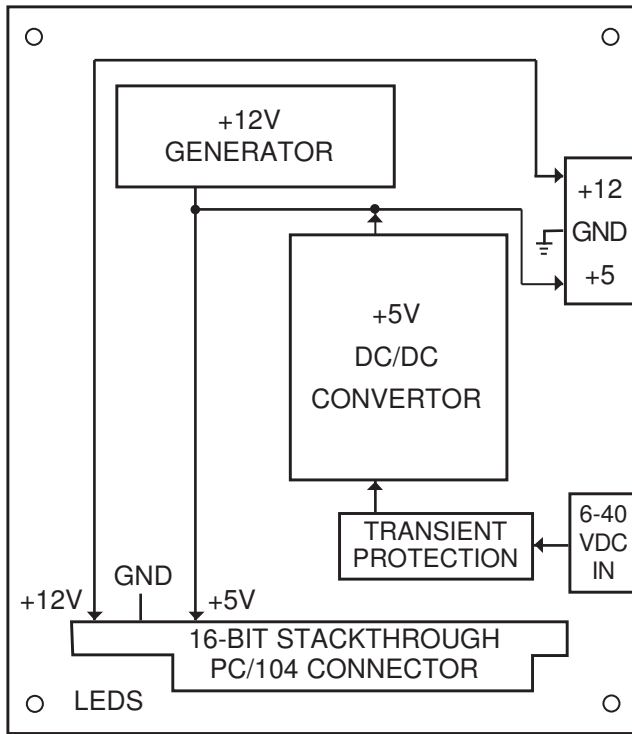

PCM-HE104-G Block Diagram

PC/104 Connector - The PCM-HE104-G is wired to the appropriate power and ground pins on the stackthrough PC/104 connector to provide power to a stack of boards. The other PC/104 Bus pins are not wired to the board and simply pass through.

Voltage	Row and Pin Number
+5V	B3, B29, D16
+12V	B9
Ground	A32, B1, B10, B31, B32, C0, D0, D18, D19

PC/104 Connector Power Assignments

Status LEDs - Two red, light emitting diodes (LEDs) are on the board to provide a visual indication of the presence or absence of both the +5VDC and +12VDC power supply voltages. The LEDs can be enabled or disabled with onboard jumpers. It is shipped with the LEDs enabled.

RoHS Compliant - The PCM-HE104-G meets the European Union issued Directive 2002/95/EC regarding the restriction of the use of certain hazardous substances in electrical and electronic equipment.

SPECIFICATIONS

Electrical

PC/104 Bus: 16-bit, stackthrough
 Input Range: 6 to 40VDC
 Maximum Input Transient: 125V for 100mS
 Output Range: +5V @ 10A (current rating includes current supplied to +12V circuit)
 +12V @ 2A
 Load Regulation*: <60mV
 Line Regulation*: ±40mV
 Output Temp. Drift*: <40mV
 Output Ripple*: <20mV
 Conducted Susceptibility*: >57dB
 Efficiency*: Up to 95%
 (*Measured on the +5V output)

Mechanical

Dimensions: 3.55" x 3.75" (90mm x 96mm)
 Weight: 6.08 oz/172.37 grams

Connectors

Input Voltage: 2-pin, 3.5mm pluggable terminal
 PC/104: 64-pin, 0.100" (32-pin double row)
 40-pin, 0.100" (20-pin double row)
 Terminal Block: 3-pin screw clamp

Environmental

Operating Temperature: -40° to +85° Celsius
 Non-condensing Relative Humidity: 5% to 95%

ORDERING INFORMATION

PCM-HE104-G RoHS-compliant, 50W PC/104 dual output DC/DC power supply
 ENC-104-1 PC/104 & PC/104-Plus enclosure

WinSystems reserves the right to make changes to products and/or documentation without further notification.

Product names of other companies may be trademarks of their respective companies.

