

FEATURES

- PC/104 compatible 56kbps modem module based upon DSP hardware chip set
- Data modem line speeds of 56kbps supporting:
 - V.90, V.34, V.32bis, V.32, V.22bis, V.23 & V.21
 - Bell 212A and Bell 103
- ECC and data compression supporting:
 - V.42 and MNP2-4 error correction
 - V.42bis and MNP5 data compression
- Integrated DAA provides compliance to global telephone standards
- AT command set supported
- Built in fuse and SiDactor
- Caller ID detection
- Parallel phone detection
- DTMF dialing
- Replacement for WinSystems' PCM-33.6
- +5VDC only operation
- Small size: 90 mm x 96 mm (3.6" x 3.8")
- Operating temperature: -40°C to +85°C
- RoHS compliant

WinSystems' PC/104 modem module is designed to directly connect to dial-up telephone lines. It supports data rates up to 56000 bps plus supports MNP error correction and data compression. The modem uses the AT command set to control the operation of the modem and its internal register settings which makes it software compatible with most application code. The PCM-MODEM56K-G-1 is pin-out compatible and a direct replacement for WinSystems' PCM-33.6 modem module. It will operate over an industrial temperature range from -40° to +85° Centigrade.

FUNCTIONAL CAPABILITY

PC/104 Bus Interface - The PCM-MODEM56K-G-1 is a 16-bit PC/104 stackthrough card with a 10-bit I/O port mapped interface. A total of 8 contiguous addresses are required in the I/O map. Its base address can be jumper selectable to the desired starting location. The data path to the module is 8-bits.

Serial Controller - A 16C552-compatible UART converts the PC/104 signals into a serial asynchronous data stream needed for the modem module. Each channel has a 16-byte transmit and receive FIFO to increase the service interval giving the external CPU additional time for other applications and reducing the overall UART interrupt servicing time. It will work with 7- or 8-bit characters and will handle 1 or 2 stop bits, even, odd, or no parity, false start bit detection, and automatic break detection.

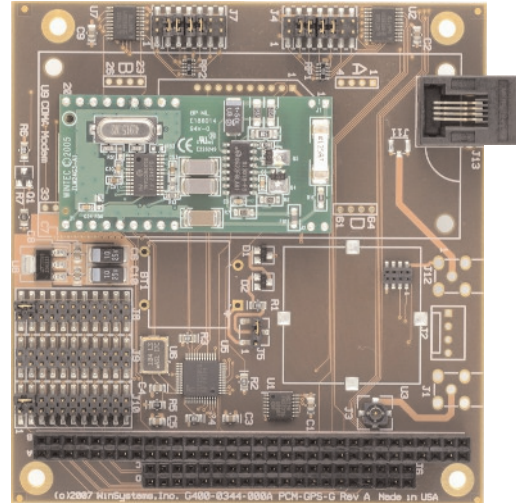

Modem - The modem part of this board is a 40-pin DIP form factor module that plugs into socket strips. It measures 2" x 1". The module is a DSP-based hardware modem, which is different from a soft modem, and is independent of the host processor. In addition to data transfer, it supports caller ID detection, parallel phone detection and global line interface.

The modem can automatically adjust its baud rate to that of the other modem so that they can communicate properly. It also supports the basic AT command set, along with many of the enhanced AT commands.

The PCM-MODEM56K-G-1 supports V.42 and MNP2-4 error correction. This error correction protocol ensures the error-free delivery of asynchronous data sent between the host and the remote end. The module also supports V.42bis and MNP5 data compression protocols.

The module also includes a Data Access Arrangement (DAA) device that can meet international telephone line requirements with compliance to FCC, CTR21 and other country-specific PTT specifications. CTR21 is a consortium of 21 countries that have developed a common modem interface specification.

The analog telephone TIP and RING lines are wired from the DAA to a standard RJ-11 connector at the board edge.

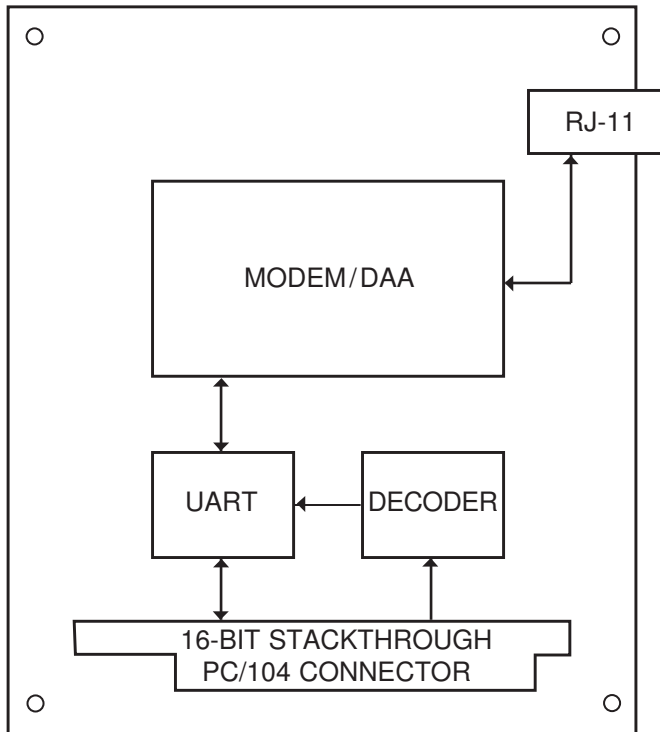

PCM-MODEM56K-G-1 Block Diagram

Over current protection - The over current protection is up to 70V and 200mA to protect the unit from being accidentally plugged into a digital phone line. Many digital PBX lines have a low impedance with a high current voltage source across the two terminals of the RJ-11 jack that is normally TIP and RING on an analog phone line. When an analog modem is plugged into a digital line, it goes Off-hook and draws excessive current and could damage the hook switch components.

The modem can detect the over-current condition to generate an interrupt for the host to force the modem into a high-impedance mode or On-hook before damage occurs.

Interrupts - Interrupts can be generated by the UART which are routed to a jumper block on the board. The PCM-MODEM56K-G-1 can select IRQ line assignment on channels 3, 4, 5, 6, 7, 9, 10, 11, 12, 14, or 15.

GPS - As a custom population option, this board can also receive GPS signals if a Lassen iQ device and antenna connector is installed at the factory. This will provide position, velocity, and very accurate time (PVT) data using the most popular standard protocols: TSIP (Trimble Standard Interface Protocol), TAIP (Trimble ASCII Interface Protocol), and NMEA 0183.

Since the modem requires that it be wired to a POTS network, the GPS function would be used as a source for very accurate time data and synchronization.

SPECIFICATIONS

Electrical

Data modem line speeds: up to 56000 bps
 Dialing: Tone (DTMF)
 Ringer Equivalence = 0.6B
 FCC Certification: WTIMMO1BSLM24
 PC/104 Bus: 16-bit, stackthrough
 Voltage: +5V 5% @ 100 mA typ.

Mechanical

Dimensions: 3.6" x 3.8" (90 mm x 96 mm)
 Weight: 2.4 oz. (68 gm.)

Connectors

Telephone: RJ-11C
 PC/104: 64-pin, 0.100" (32-pin double row)
 40-pin, 0.100" (20-pin double row)
 Jumpers: 0.020" square posts on 2 mm centers

Environmental

Operating Temperature: -40° to +85° Celsius
 Non-condensing relative humidity: 5% to 95%

ORDERING INFORMATION

PCM-MODEM56K-G-1 56kbps PC/104 Modem

WinSystems reserves the right to make changes to products and/or documentation without further notification.

Product names of other companies may be trademarks of their respective companies.

