

FEATURES

- Supports up to 2MB of SRAM, PEROM (Flash) EPROM, or battery-backed SRAM per board
- Four byte-wide memory sockets will accept 128K x 8, 256K x 8, or 512K x 8 SRAMs, EPROMs or PEROMs (+5V only Flash memory)
- Software controlled "Write Protect"
- Powerfail/brownout battery switching RAM protection circuits
- I/O mapped board requires no system memory and only 8 contiguous I/O ports
- Up to 8 boards can be mapped together to provide 16MB of contiguous storage per solid state disk
- Multiple solid state disks can be supported by a single PCM-SSD module
- RAM/EPROM/PEROM disk driver software available for DOS and ROM-DOS systems
- EPROM socket supports BIOS extension for bootable systems
- MKDISK utility for creating ROMDISKs
- High speed data access and storage
- Onboard battery power for SRAM support
- Single +5 volt operation
- 0°C to +70°C operational temperature range

The PCM-SSD is an I/O mapped, universal PC/104 Bus Solid State Disk (SSD) module. It can be populated by the user with up to 2 megabytes of RAM, EPROM, or PEROM (Flash). The card allows a user to substitute onboard semiconductor devices in applications where the environment is too harsh for mechanical hard disks or floppy disk drives, plus it has significant speed advantages. It is designed to store programs and data for applications such as data collection and logging, diagnostics, etc.

FUNCTIONAL CAPABILITY

PC/104 Interface - The PCM-SSD is I/O port mapped. Therefore it does not require any memory in the 1 megabyte main system memory map. The I/O address is jumper selectable starting at a base address of 210 or 218 hexadecimal.

Five I/O registers allow the writing of the RAM array addresses, the data access, and the Write Protect function. The memory is accessed through a single I/O address which is autoincremented to the next address so that high speed string move instructions can be utilized for reading or writing blocks of data. The PCM-SSD offers nearly instantaneous data access since there is no track-to-track seeking.

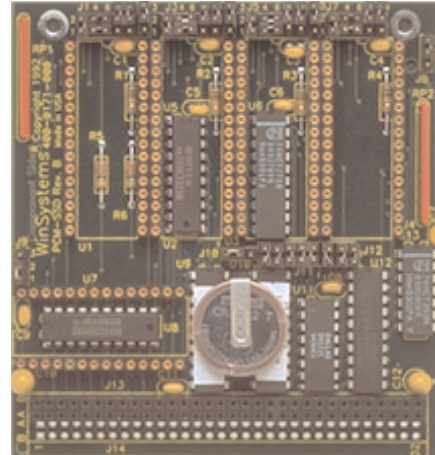

Up to 8 boards can be mapped at the same port block to provide up to 16MB of solid state storage. An additional 16MB SSD drive can be mapped to the alternate I/O port map if more storage is required.

RAM/ROM Disk Storage Capacity - The standard PCM-SSD is unpopulated and has four, 32-pin byte-wide memory sockets that will accept 128K x 8, 256K x 8, or 512K x 8 SRAMs, EPROMs, or PEROMs (+5 volt only Flash memory) for a total of up to 2 megabytes per board. Mixing of ROM, PEROMs, and RAMs are permitted on a per socket basis although all devices must be of the same capacity. The battery can also be enabled at each individual memory socket as required.

BIOS Configuration Socket - A fifth memory socket is onboard which provides a BIOS extension ROM. When enabled, it allows the PCM-SSD to become a bootable disk containing either RAMs or ROMs.

ROMDISK - A diskette imaging program called MKDISK is provided to simplify the creation of a bootable ROMDISK made from a floppy diskette. Since the bootable ROMDISK is an exact image of a bootable floppy diskette, all testing and debugging can be accomplished using a floppy drive. Once the application is ready for ROM, it is a simple matter to use the MKDISK utility to create the EPROMs necessary for a bootable ROMDISK equivalent of the functioning floppy. The PCM-SSD populated with programmed EPROMs and the BIOS extension will create a bootable ROMDISK.

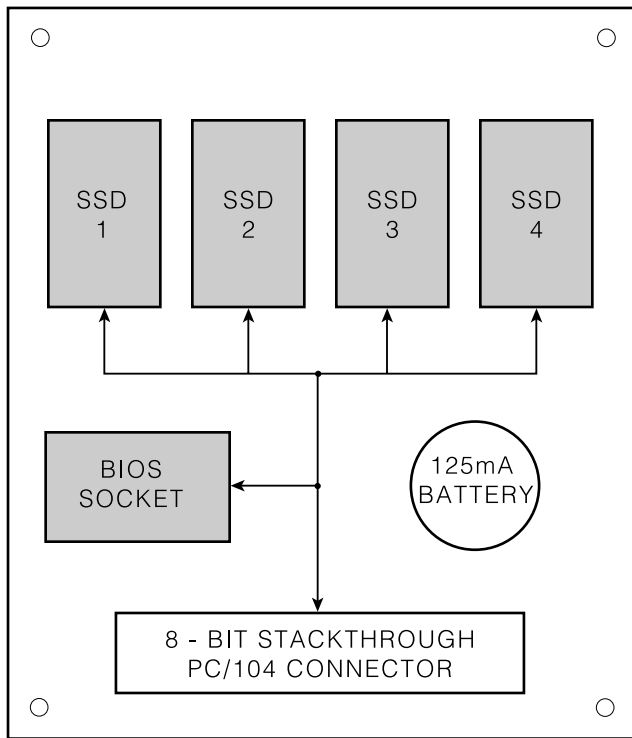

*SHADING INDICATES SOCKET ONLY

PCM-SSD BLOCK DIAGRAM

RAMDISK - The RAMDISK is available as a bootable device using the BIOS extension or as a non-bootable disk by using an installable device driver. By using the standard MS-DOS Format program, a bootable RAMDISK can be created in a floppy disk size of up to 2.88 megabytes. The PCM-SSD (with the onboard 125 mA-hour battery enabled to the memory sockets) can be populated by the user with up to four, 128KB, 256KB or 512KB low power CMOS SRAMs for a total of up to 2MB per board.

USSD.SYS is an installable device driver which is supplied with the board that can be used with MS-DOS and ROM-DOS operating systems. It supports disk sizes up to 16 megabytes per drive. The driver supports both PEROMs (Flash) and battery-backed SRAMs on a per socket basis.

The PCM-SSD can also be configured and supports multiple disk drives on a single card.

Write Protection Register - The PCM-SSD board includes a special protection circuit for use with SRAM and PEROMs (Flash) devices. Upon power up, each memory device's Write line (if applicable) is disabled. It must be specifically enabled by a software command. Both WinSystems' USSD.SYS device driver, as well as the USSD BIOS extension, will enable writing to the PCM-SSD module only when a sector is being transferred, protecting the safety and integrity of the data.

SPECIFICATIONS

Electrical

Bus: PC/104 compatible, 8-bit stackthrough
 Addressing: 20/24-bit for BIOS socket
 10-bit I/O for the four, 32-pin sockets
 Power required with no memory installed
 ±5% @ 100mA

Memory Capacity: Four, 32-pin byte-wide sockets for
 128KB, 256KB, 512KB EPROMs, SRAMs
 or Flash PEROMs

Battery: 125 mA-Hour Lithium

Mechanical

Dimensions: 3.6" x 3.8" (90mm x 96mm)

Environmental

Operating temperature: -40°C to +85°C
 Non-condensing relative humidity: 5% to 95%

ORDERING INFORMATION

PCM-SSD 2MB Solid State Disk PC/104 Module
 (with no memory installed)

