

# **OPERATIONS MANUAL**

## **ANALOG TERMINATOR**

WinSystems, Inc. reserves the right to make changes in the circuitry and specifications at any time without notice.

**COPYRIGHT 1991 WinSystems, Inc.**  
**All Rights Reserved**

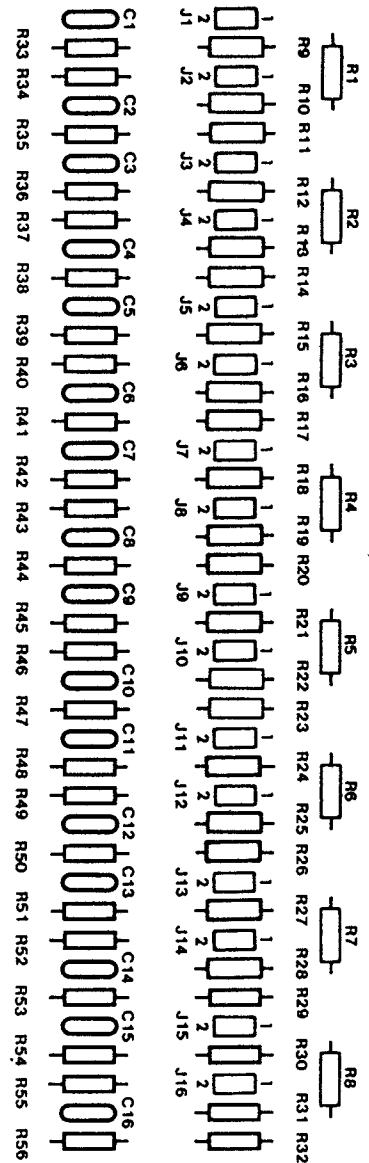
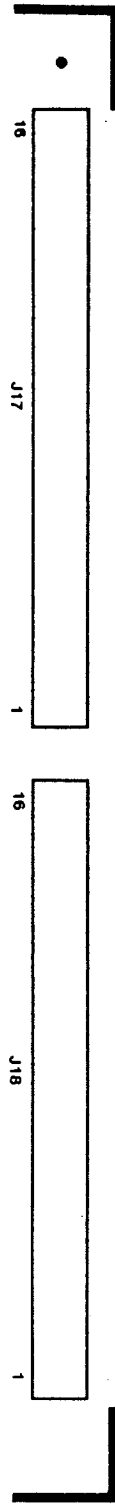

ANALOG ADAPTOR  
400-0080-000 REV A

WINSYSTEMS INC.  
MADE IN U.S.A.  
© 1988

COMPONENT LAYOUT

ANALOG-ADP REV A



10/14/91  
08:53:51

Parts List  
WinSystems, Inc.

BEGINNING RANGE: ANALOG-ADP

ENDING RANGE: ANALOG-ADP

LEVEL	ITEM KEY	ITEM DESCRIPTION	BOM DESCRIPTION	LOC	OVHD KEY	ITEM TYPE	QTY REQUIRED
1	ANALOG-ADP	ANALOG ADAPTER					1
2	0080-200-0000	ASSY ANALOG ADAPTER REV A	ASSY ANALOG ADAPTER REV A	ARLIN		Inv	1
3	>999-9999-001	SPECIAL NOTES	3-01-91	ARLIN		Inv	1
3	>201-0026-121	HDR 26 POS RA IDH-26LP-SR3-TG/TR	J19	ARLIN		Inv	1
3	>201-0036-010	HDR 1X36 UN TSW-136-07-G-S	J1-J16=2X1	ARLIN		Inv	.888
3	>202-0016-000	SCREW TERM 8281/16025.104.1653 E	J17,J18	ARLIN		Inv	2
3	>400-0080-000	PCB ANALOG TERMINATOR REV A		ARLIN		Inv	1
2	950-0001-000	BAG ANTISTATIC 6X10 CHARLES WATE	BAG ANTISTATIC 6X10 CHARLES WATER CP303	ARLIN		Inv	1

REPORT RECAP

0 WARNING(S) \* Indicates no BOM Found for Item  
0 ERROR(S)

REPORT PARAMETERS

ASSEMBLY RANGE : ANALOG-ADP to ANALOG-ADP  
TYPE : <ALL>  
COMPONENT RANGE : <FIRST> to <LAST>  
TYPE : RWF  
MASKING : Inv-Explode Specific Inv Items (No Masks)  
QUANTITY (TO EXPLODE): 1

DESC LENGTH: ITEM : 32  
COMMENT : 40  
LOCATION: 0  
OVERHEAD: 0  
NESTING INDENT LENGTH: 20  
TOTAL REPORT WIDTH : 132

4

3

2

1

REVISIONS				
ZONE	LTR	DESCRIPTION	DATE	APPROVED

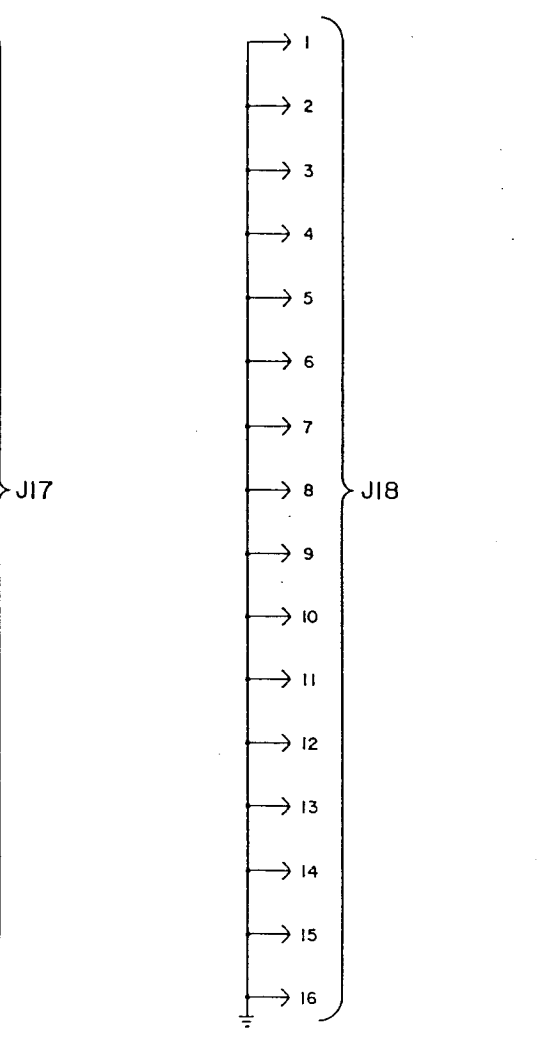
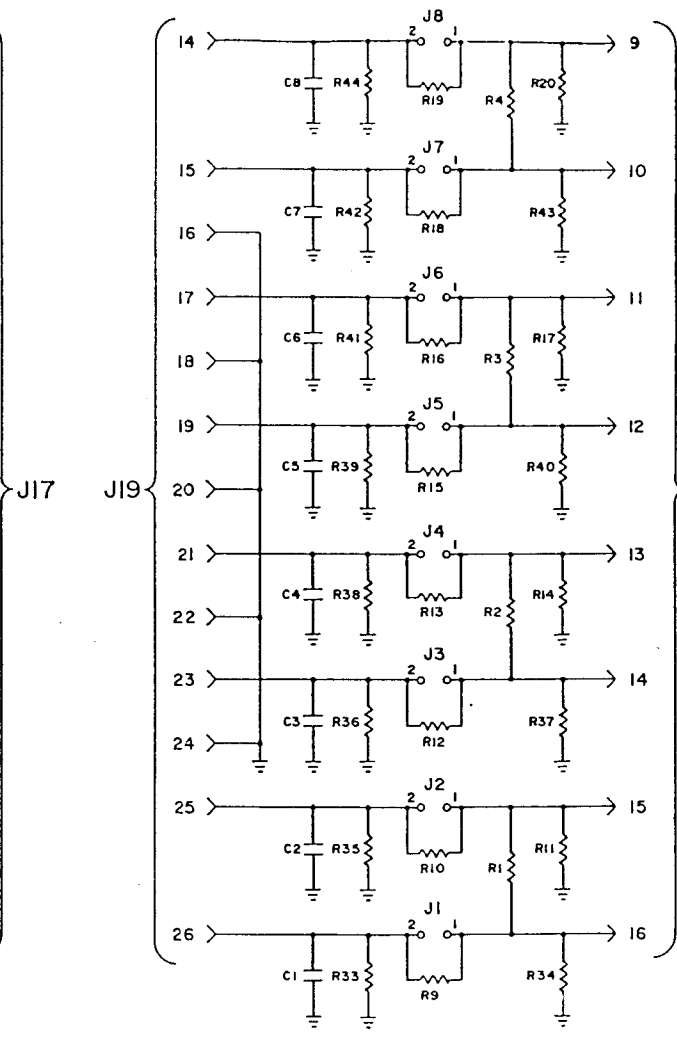
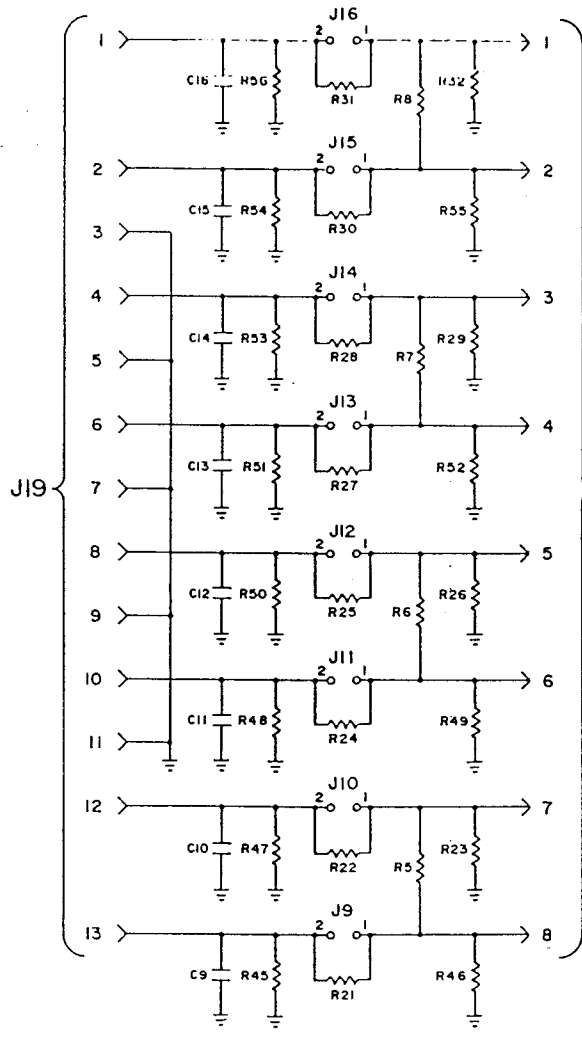

D  
C  
B

UNLESS OTHERWISE SPECIFIED  
DIMENSIONS ARE IN INCHES  
TOLERANCES: FRACTIONS: ±  
DECIMALS: ANGLES: ±

.XX ±  
.XXX ±

NEXT ASST	USED ON	APPROVED
APPLICATION		RELEASE

CONTRACT NO:

PREPARED		
APPROVED		
RELEASE		

**WinSystems, Inc.**  
Arlington, Texas

**ANALOG ADAPTOR  
SCHEMATIC**

SIZE <b>C</b>	DRAWING NO. <b>401-0080-000</b>
SCALE	REV A      SBT 1 OF 1

A

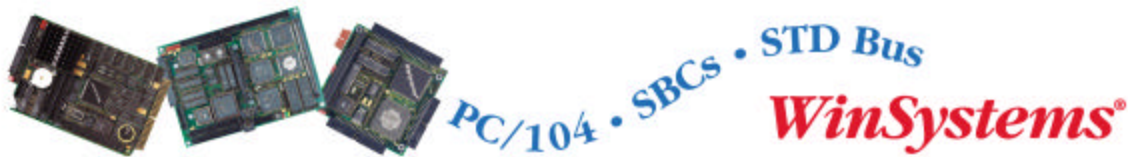

Telephone: 817-274-7553 • Fax: 817-548-1358  
<http://www.winsystems.com> • E-mail: [info@winsystems.com](mailto:info@winsystems.com)

## WARRANTY

WinSystems warrants that for a period of two (2) years from the date of shipment any Products and Software purchased or licensed hereunder which have been developed or manufactured by WinSystems shall be free of any material defects and shall perform substantially in accordance with WinSystems' specifications therefore. With respect to any Products or Software purchased or licensed hereunder which have been developed or manufactured by others, WinSystems shall transfer and assign to Customer any warranty of such manufacturer or developer held by WinSystems, provided that the warranty, if any, may be assigned. The sole obligation of WinSystems for any breach of warranty contained herein shall be, at its option, either (i) to repair or replace at its expense any materially defective Products or Software, or (ii) to take back such Products and Software and refund the Customer the purchase price and any license fees paid for the same. Customer shall pay all freight, duty, broker's fees, insurance charges and other fees and charges for the return of any Products or Software to WinSystems under this warranty. WinSystems shall pay freight and insurance charges for any repaired or replaced Products or Software thereafter delivered to Customer within the United States. All fees and costs for shipment outside of the United States shall be paid by Customer. The foregoing warranty shall not apply to any Products or Software which have been subject to abuse, misuse, vandalism, accidents, alteration, neglect, unauthorized repair or improper installations.

**THERE ARE NO WARRANTIES BY WINSYSTEMS EXCEPT AS STATED HEREIN. THERE ARE NO OTHER WARRANTIES EXPRESS OR IMPLIED INCLUDING, BUT NOT LIMITED TO, THE IMPLIED WARRANTIES OF MERCHANTABILITY AND FITNESS FOR A PARTICULAR PURPOSE, IN NO EVENT SHALL WINSYSTEMS BE LIABLE FOR CONSEQUENTIAL, INCIDENTAL, OR SPECIAL DAMAGES INCLUDING, BUT NOT LIMITED TO, DAMAGES FOR LOSS OF DATA, PROFITS OR GOODWILL. WINSYSTEMS' MAXIMUM LIABILITY FOR ANY BREACH OF THIS AGREEMENT OR OTHER CLAIM RELATED TO ANY PRODUCTS, SOFTWARE, OR THE SUBJECT MATTER HEREOF, SHALL NOT EXCEED THE PURCHASE PRICE OR LICENSE FEE PAID BY CUSTOMER TO WINSYSTEMS FOR THE PRODUCTS OR SOFTWARE OR PORTION THEREOF TO WHICH SUCH BREACH OR CLAIM PERTAINS.**

## WARRANTY SERVICE

All products returned to WinSystems must be assigned a Return Material Authorization (RMA) number. To obtain this number, please call or FAX WinSystems' factory in Arlington, Texas and provide the following information:

1. Description and quantity of the product(s) to be returned including its serial number.
2. Reason for the return.
3. Invoice number and date of purchase (if available), and original purchase order number.
4. Name, address, telephone and FAX number of the person making the request.
5. Do not debit WinSystems for the repair. WinSystems does not authorize debits.

After the RMA number is issued, please return the products promptly. Make sure the RMA number is visible on the outside of the shipping package.

The customer must send the product freight prepaid and insured. The product must be enclosed in an anti-static bag to protect it from damage caused by static electricity. Each bag must be completely sealed. Packing material must separate each unit returned and placed as a cushion between the unit(s) and the sides and top of the shipping container. WinSystems is not responsible for any damage to the product due to inadequate packaging or static electricity.