

# **OPERATIONS MANUAL**

## **LPM/MCM-MDVGA**

WinSystems reserves the right to make changes in the circuitry  
and specifications at any time without notice.  
© Copyright 1997 by WinSystems. All Rights Reserved.

**REVISION HISTORY**

**P/N 403-0258-000**

ECO Number	Date Code	Rev Level
ORIGINATED	970613	C
01-29	010518	C1

# TABLE OF CONTENTS

Section Number	Paragraph Title	Page Number
1	General Information	
1.1	Features	1-1
1.2	Specifications	1-2
2	LPM/MCM-MDVGA Technical Reference	
2.1	Introduction	2-1
2.2	Interrupt Routing	2-1
2.3	Multi-Video Configuration	2-2
2.4	BIOS ROM Type Selection	2-4
2.5	CRT Output Connection	2-5
2.6	Flat Panel Output Connection	2-6
2.7	Video Mode Tables	2-7
2.8	Connector/Jumper Summary	2-9
APPENDIX A	LPM/MCM-MDVGA Parts Placement Guide	
APPENDIX B	LPM/MCM-MDVGA Parts List	
APPENDIX C	LPM/MCM-MDVGA Schematic Diagrams	

# 1 General Information

## 1.1 Features

- 16-Bit STD-BUS CRT/Flat Panel VGA Controller
- Uses the CHIPS™ 65545 High Performance Video Controller
- Supports CRT outputs of up to 1024 X 768 with 256 colors
- Supports Flat Panel resolutions up to 1024 X 768
- High-Performance zero wait-state writes
- Supports Tru-Color and Hi-Color displays of up to 640 X 480
- Optional Multi-Video Support
- SMARTMAP intelligent color to gray scale conversion
- Fully IBM VGA compatible
- Optional FPA adapter modules for Flat Panel use

## 1.2 General Description

The MD-VGA is a third generation CRT/Flat Panel controller board. It supports standard VGA output to a CRT monitor as well as to a variety of flat panel displays using optional Flat Panel Adapter (FPA) modules. Optional support for Multi-Video display is also available. The MDVGA uses the Chips and Technologies 6554X series of high-performance VGA controllers. This CHIPS™ controller supports standard and Super-VGA modes as well as Color and Monochrome panels with 8,9,12,15,16,18, and 24-bit interfaces. WinSystems provides flat panel support for the MDVGA through a series of FPA (Flat Panel Adapter) modules. Contact your WinSystems Applications Engineer for the most current list of available FPAs and supported panels.

## **1.3 Specifications**

### **1.3.1 Electrical**

Bus Interface :	STD-BUS 16-Bit interface
VCC :	+5V +/-5% @ 300mA typical w/CRT output and 512KB video RAM
VCC1	+12V +/-5% FPA Modules only
VCC2 :	-12V +/-5% FPA Modules only

### **1.3.2 Mechanical**

Dimensions :	4.5" X 6.5" X 0.6"
PC Board :	FR4 Epoxy Glass with 2 signal layers and 2 power planes with screened component legend, plated through holes, and gold plated fingers.
Jumpers :	0.025" square posts on 0.10" centers
Connectors :	CRT : DB15F or 10 pin RN type IDH-10-LP Panel Interface : 50 pin RN type IDH-50-LP

### **1.3.3 Environmental**

Operating Temperature :	0° to 70° C MCM-MDVGA -40° to +85° C LPM-MDVGA
Non-condensing relative humidity :	5% to 95%

# 2

## LPM/MCM-MDVGA Technical Reference

### 2.1 Introduction

The MDVGA is a fully IBM compatible display module capable of CRT or Flat Panel output. Optional FPA (Flat Panel Adapter) modules allow for easy interfacing to a variety of color and monochrome Flat Panel displays. Details regarding interfacing to specific Flat Panels is not provided in this manual but should be referenced in the documentation accompanying the FPA module. Attempted connection to any flat panel not directly supported by a WinSystems FPA module is at the user's risk and extreme care should be exercised to avoid damaging or destroying the panel. To request assistance with the MDVGA or the WinSystems FPA, modules contact the Technical Support Group at (817) 274-7553 between 8AM and 5PM Central Time.

**Hazard Warning :** LCD panels can require a high voltage for the panel backlight. This high-frequency voltage can exceed 1000 volts and can present a shock hazard. To avoid danger of shock and to avoid damaging fragile and expensive panels, make all connection changes with the power removed.

### 2.2 Interrupt Routing

To maintain compatibility with older EGA software, a retrace interrupt is available by placing a jumper on J7. J7 allows for the selection of any of 4 STD-BUS backplane pins over which the retrace interrupt can be routed. The MDVGA is shipped from the factory with no jumper on J7 which is compatible with all modern VGA modes.

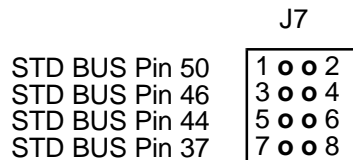

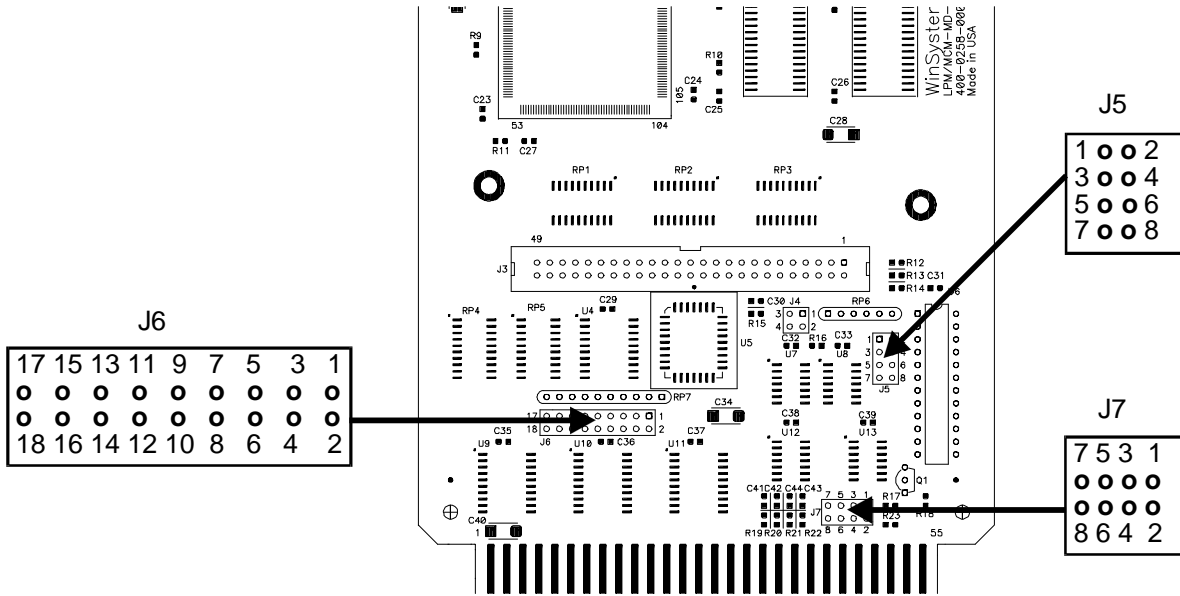

## 2.3 Multi-Video Configuration

When the multi-video option is populated, up to 15 MDVGA boards may be simultaneously installed and individually controlled by software. The I/O address of the board select register is controlled by jumper block J6. All boards installed in the same system must be set to the same I/O address. The address is selected as shown below :

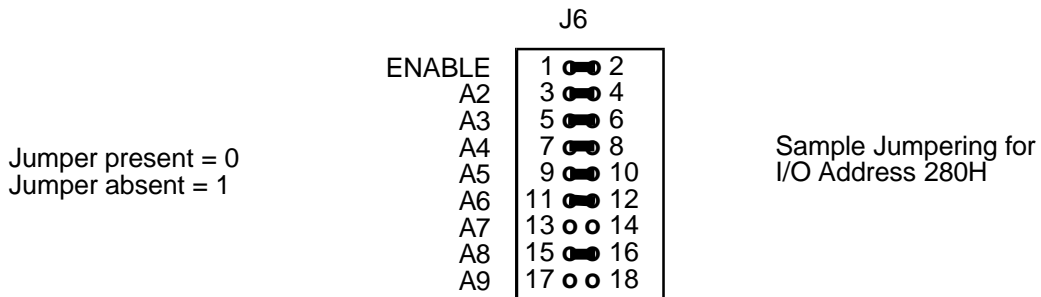

**2.3.1** Board ID Select

Up to 15 boards can be installed in a single system. Each board must be jumpered with a unique board ID number between 1 and 15. This board ID is selected with the jumper block at J5. When using only a single board, select board number 1 and remove the enable jumper at pins 1-2 of J6. When multiple boards are used, ID numbers must be assigned beginning with 1, and preceding sequentially. The jumpering detail for J5 is shown below :

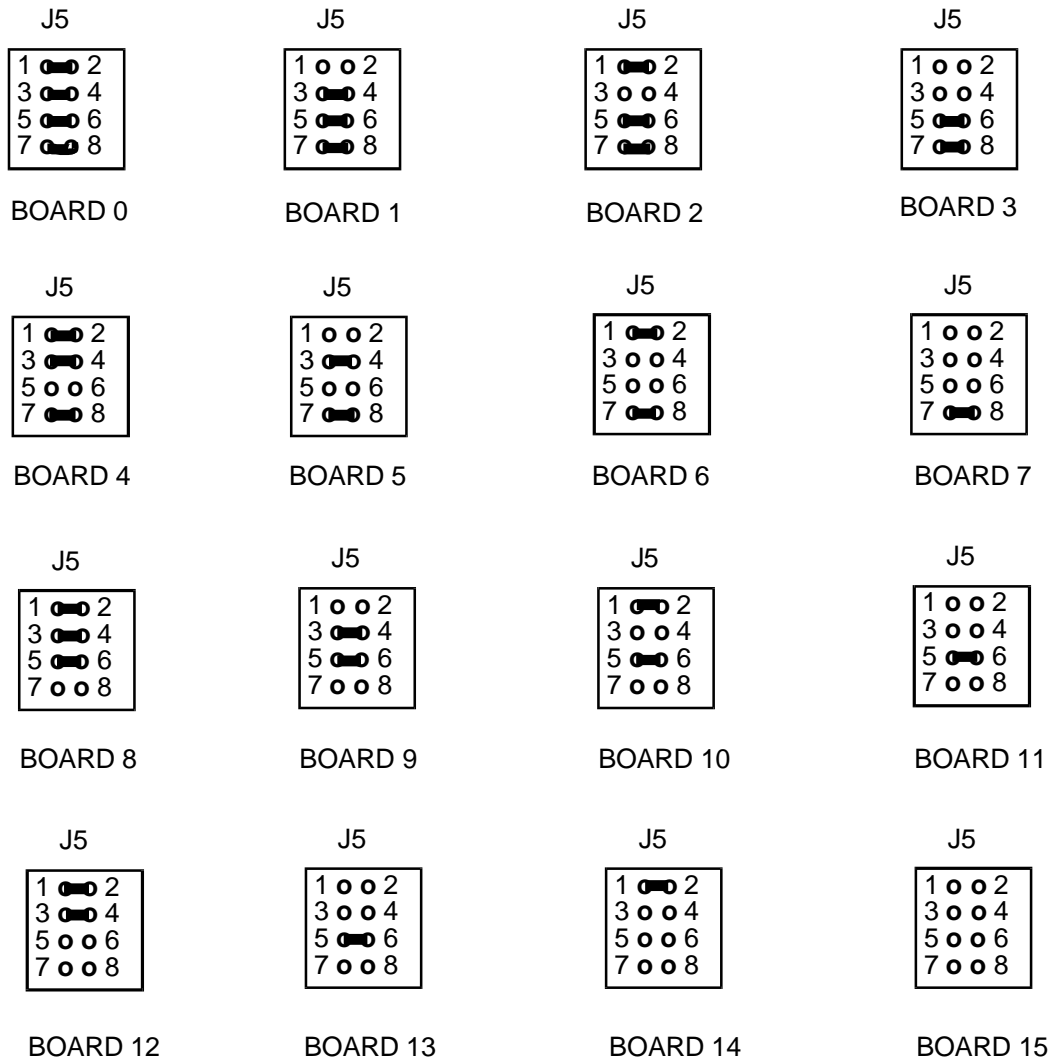

## 2.4 BIOS ROM Type Selection

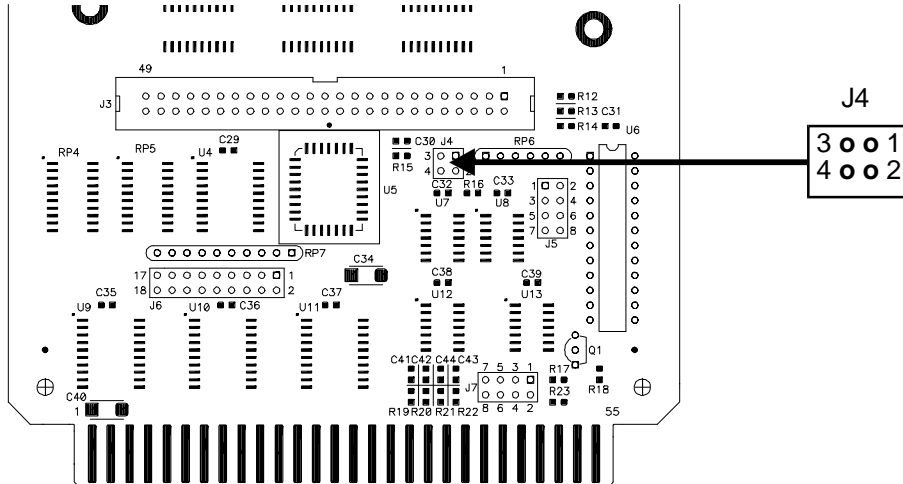

The MDVGA comes standard with a video BIOS expansion ROM populated at U5. Various ROM sizes can be used to support a variety of flat panel configurations each needing its own BIOS image. The FPA modules automatically select the correct BIOS image for the Panel family when the FPA is installed onto J3. The factory will ordinarily configure the BIOS ROM select jumper(s) for the BIOS ROM size provided. The jumpering details for J4 are shown here :



## 2.5 CRT output connection

The MDVGA supports connection to standard VGA monitors through connectors at both J1 and J2. J1 is a dual-row 10-pin header to which the WinSystems adapter cable P/N CBL-207-1 may be attached. This allows for remote mounting of the CRT connector. Also provided is J2 is a standard DB15 VGA connector, for direct attachment of a VGA monitor. The pin definitions for J1 and J2 are shown here :



## 2.6 Flat Panel Output Connection

Connection to all flat panels is made via the 50-pin connector at J3. This connector is cabled to the appropriate FPA (Flat Panel Adapter) module which then breaks out the necessary cabling for attachment to the panel itself. The FPA module also supplies any special controls that may be needed for the panel. Refer to the FPA documentation for specific hook-up instructions. The pin definitions for the J3 connector are shown here.

J3		
SW0	1 ○ ○ 2	SW1
SW2	3 ○ ○ 4	SW3
P23	5 ○ ○ 6	P22
P21	7 ○ ○ 8	P20
P19	9 ○ ○ 10	P18
GND	11 ○ ○ 12	GND
P17	13 ○ ○ 14	P16
P15	15 ○ ○ 16	P14
P13	17 ○ ○ 18	P12
GND	19 ○ ○ 20	GND
P11	21 ○ ○ 22	P10
P9	23 ○ ○ 24	P8
P7	25 ○ ○ 26	P6
GND	27 ○ ○ 28	GND
P5	29 ○ ○ 30	P4
P3	31 ○ ○ 32	P2
P1	33 ○ ○ 34	P0
GND	35 ○ ○ 36	GND
SHFCLK	37 ○ ○ 38	LP
FLM	39 ○ ○ 40	M
ENVCC	41 ○ ○ 42	ENBKL
ENVEE	43 ○ ○ 44	PHS
PVS	45 ○ ○ 46	-12V
+12V	47 ○ ○ 48	+12V
VCC	49 ○ ○ 50	VCC

## 2.7 Video Mode Tables

The MD-VGA supports a number of standard and extended VGA modes. The following tables extracted from the CHIPS 65540/65545 databook shows the video modes along with the required amount of RAM.

### Standard Video Modes - VGA Standard

Mode # (Hex)	Display Mode	Colors	Text Display	Font Size	Pixel Resolution	Dot Clock (MHz)	Horizontal Frequency (KHz)	Vertical Frequency (Hz)	Video Memory	CRT CODE
0+, 1+	Text	16	40 X 25	9 X 16	360 X 400	28.322	31.5	70	256KB	A,B,C
			40 X 25	8 X 14	320 X 350	25.175				
			40 X 25	8 X 8	320 X 200	25.175				
2+, 3+	Text	16	80 X 25	9 X 16	720 X 400	28.322	31.5	70	256KB	A,B,C
			80 X 25	8 X 14	640 X 350	25.175				
			80 X 25	8 X 8	620 X 200	25.175				
4	Graphics	4	40 X 25	8 X 8	320 X 200	25.175	31.5	70	256KB	A,B,C
5	Graphics	4	40 X 25	8 X 8	320 X 200	25.175	31.5	70	256KB	A,B,C
6	Graphics	2	80 X 25	8 X 8	640 X 200	25.175	31.5	70	256KB	A,B,C
7+	Text	Mono	80 X 25	9 X 16	720 X 400	28.322	31.5	70	256KB	A,B,C
			80 X 25	9 X 14	720 X 350					
			80 X 25	9 X 8	720 X 350					
D	Planar	16	40 X 25	8 X 8	320 X 200	25.175	31.5	70	256KB	A,B,C
E	Planar	16	80 X 25	8 X 8	640 X 200	25.175	31.5	70	256KB	A,B,C
F	Planar	Mono	80 X 25	8 X 14	640 X 350	25.175	31.5	70	256KB	A,B,C
10	Planar	16	80 X 25	8 X 14	640 X 350	25.175	31.5	70	256KB	A,B,C
11	Planar	2	80 X 30	8 X 16	640 X 480	25.175	31.5	60	256KB	A,B,C
12	Planar	16	80 X 30	8 X 16	640 X 480	25.175	31.5	60	256KB	A,B,C
13	Packed Pixel	256	40 X 25	8 X 8	320 X 200	25.175	31.5	70	256KB	A,B,C

#### CRT Codes

A - PS/2 Fixed-frequency analog CRT or equivalent (31.5/35.5 Khz Horizontal Frequency Specification)

B - Multi-Frequency CRT Monitor (37.5 Khz minimum Horizontal Frequency Specification) (NEC MultiSync 3D or equivalent)

C - Multi-Frequency High-Performance CRT Monitor (48.5 KHZ minimum Horizontal Frequency Specification) MultiSync 5D or equivalent

## Extended Resolution Modes

Mode # (Hex)	Display Mode	Colors	Text Display	Font Size	Pixel Resolution	Dot Clock (MHz)	Horizontal Frequency (KHz)	Vertical Frequency (Hz)	Video Memory	CRT CODE
20	4-Bit Linear	16	80 X 30	8 X 16	640 X 480	25.175	31.5	60	512KB	A,B,C
22	4-Bit Linear	16	100 X 37	8 X 16	800 X 600	40.00	37.5	60	512KB	B,C
24	4-Bit Linear	16	128 X 48	8 X 16	1024 X 768	65.00	48.5	60	512KB	C
24I						44.90	35.5	43	512KB	B,C
30	8-Bit Linear	256	80 X 30	8 X 16	640 X 480	25.175	31.5	60	512K	A,B,C
32	8-Bit Linear	256	100 X 37	8 X 16	800 X 600	40.00	37.5	60	512KB	B,C
34	8-Bit Linear	256	128 X 48	8 X 16	1024 X 768	65.00	48.5	60	1MB	C
34I						44.90	35.5	43	1MB	B,C
40	16-Bit Linear	32K	80 X 30	8 X 16	640 X 480	50.350	31.5	60	1MB	A,B,C
41	16-Bit Linear	64K	80 X 30	8 X 16	640 X 480	50.350	31.5	60	1MB	A,B,C
50	24-Bit Linear	16M	80 X 30	8 X 16	640 X 480	65.00	27.1	51.6	1MB	B,C
60	Text	16	132 X 25	8 X 16	1056 X 400	40.00	30.5	68	256KB	A,B,C
61	Text	16	132 X 50	8 X 16	1056 X 400	40.00	30.5	68	256KB	A,B,C
6A,70	Planar	16	100 X 37	8 X 16	800 X 600	40.00	38.0	60	256KB	B,C
72,75	Planar	16	128 X 48	8 X 16	1024 X 768	65.00	48.5	60	512KB	C
72,75I						44.90	35.5	43	512KB	B,C
78	Packed Pixel	16	80 X 25	8 X 16	640 X 400	25.175	31.5	70	256KB	A,B,C
79	Packed Pixel	256	80 X 30	8 X 16	640 X 480	25.175	31.5	60	512KB	A,B,C
7C	Packed Pixel	256	100 X 37	8 X 16	800 X 600	40.00	37.5	60	512KB	B,C
7E	Packed Pixel	256	128 X 48	8 X 16	1024 X 768	65.00	48.5	60	1MB	C
7EI	Packed Pixel					44.90	35.5	43	1MB	B,C

Support for the modes above is included directly in the BIOS. The 'I' in the mode # column indicates "interlaced"

## CRT Codes

A - PS/2 Fixed frequency analog CRT or equivalent (31.5/35.5 KHz Horizontal Frequency Specification)  
 B - Multi-Frequency CRT Monitor (37.5 KHz minimum Horizontal Frequency Specification) (NEC MultiSync 3D or equivalent)  
 C - Multi-Frequency High-Performance CRT Monitor (48.5 KHz minimum Horizontal Frequency Specification) MultiSync 5D or equivalent

## High Refresh Modes

Mode # (Hex)	Display Mode	Colors	Text Display	Font Size	Pixel Resolution	Dot Clock (MHz)	Horizontal Frequency (KHz)	Vertical Frequency (Hz)	Video Memory	CRT CODE
12	Planar	16	80 X 30	8 X 16	640 X 480	31.50	37.5	75	256KB	B,C
30	8-Bit Linear	256	80 X 30	8 X 16	640 X 480	31.50	37.5	75	256KB	C
79	Packed Pixel	256	80 X 30	8 X 16	640 X 480	31.50	37.5	75	512KB	C
6A,70	Planar	16	100 X 37	8 X 16	800 X 600	49.50	46.9	75	512KB	C
32	8-Bit Linear	256	100 X 37	8 X 16	800 X 600	49.50	46.9	75	1MB	C
7C	Packed Pixel	256	100 X 37	8 X 16	800 X 600	49.50	46.9	75	1MB	C

Support for the modes above is included directly in the BIOS. The 'I' in the mode # column indicates "interlaced"

## CRT Codes

A - PS/2 Fixed frequency analog CRT or equivalent (31.5/35.5 KHz Horizontal Frequency Specification)

B - Multi-Frequency CRT Monitor (37.5 KHz minimum Horizontal Frequency Specification) (NEC MultiSync 3D or equivalent)

C - Multi-Frequency High-Performance CRT Monitor (48.5 KHZ minimum Horizontal Frequency Specification) MultiSync 5D or equivalent

## 2.8 Connector/Jumper Summary

Connector/Jumper	Description	Page Reference
J1	VGA output connector	2-5
J2	VGA output connector	2-5
J3	FPA-50 Panel Interface connector	2-6
J4	BIOS Size select jumper	2-4
J5	Board ID select jumper	2-3
J6	I/O Address select jumper	2-2
J7	Interrupt Routing select jumper	2-1

# 3 APPENDIX A

## LPM/MCM-MDVGA Parts Placement Guide

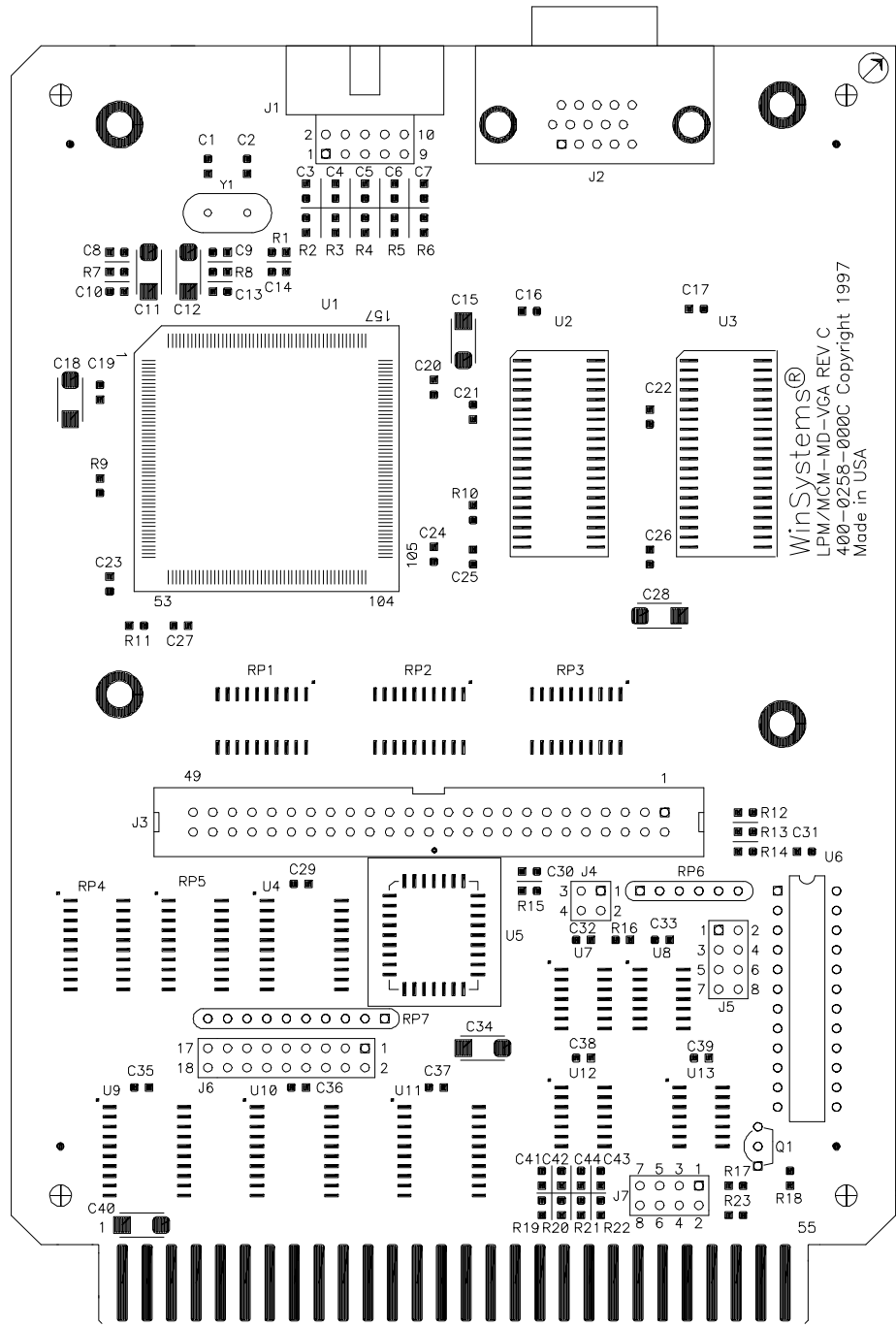

# **4** **APPENDIX B**

LPM/MCM-MDVGA Parts List

05/18/01  
13:39:56

BOM for Manuals  
WinSystems, Inc.

PAGE 1

ASSM ITEM FROM: LPM-MDVGA-1M  
PARENT LOC FROM: <FIRST>

DEFAULT COMPONENT LOCATION: ARLIN

ASSM ITEM THRU: LPM-MDVGA-1M  
PARENT LOC THRU: <LAST>

LVL	ITEM KEY	ITEM DESCRIPTION	BOM COMMENT	ITEM TYPE	QTY REQUIRED
	LPM-MDVGA-1M	CMOS STD BUS MULTIDISPLAY SVGA	CMOS STD BUS MULTIDISPLAY SVGA	CO	F 1.0
1	999-9999-001	SPECIAL NOTES	06-30-97 MEB (NEW-REV.C)	I	1.0
1	0258-130-0000C	ASSY MDVGA-1M REV.C		F	1.0
2	999-9999-001	SPECIAL NOTES	11-24-97 MEB ECO 97-114	I	1.0
2	999-9999-001	SPECIAL NOTES	05-08-97 MEB (REVC)	I	1.0
2	603-2207-403	CAP 22pF 50v 1% NPO 0805	C1-C7	I	7.0
2	603-1047-803	CAP .1uF 50v 20% CER 0805	C8-C10,C13,C14,C16,C17,C19-C27,C29-C33,	I	26.0
2	999-9999-001	SPECIAL NOTES	C35-C39	I	1.0
2	603-1065-82D	CAP 10uF 25v 20% TAN 6032	C11,C12,C15,C18,C28,C34,C40	I	7.0
2	603-4707-803	CAP 47pF 50v 20% CER 0805	C42-C44	I	3.0
2	201-0010-121	HDR 10 RA IDH-10LP-SR3-TR (1,200)	J1	I	1.0
2	201-0015-300	CON PC MT FE 15 MCRO D 302-122-106A I/OI	J2	I	1.0
2	201-0050-021	HDR 50 ST IDH-50LP-S3-TR (504)	J3	I	1.0
2	201-0072-120	HDR 2X36 UN TSW-136-07-G-D	J4=2X2 J7=2X4	I	.2
2	125-0001-000	TRANSISTOR PN2222 (TO92)	Q1	I	1.0
2	602-0220-523	RN 22 Oh, 5%, 20P, 10R, ISO	RP1-RP5	I	5.0
2	601-0103-503	RES 10K Ohm 5% 1/10W 0805	R1,R9,R12,R13-R16	I	7.0
2	601-0151-503	RES 150 Ohm 5% 1/10w 0805	R2-R4	I	3.0
2	601-0220-503	RES 22 Ohm 5% 1/10w 0805	R5,R6	I	2.0
2	601-0100-503	RES 10 Ohm 5% 1/10w 0805	R7,R8	I	2.0
2	601-0472-503	RES 4.7K Ohm 5% 1/10w 0805	R10	I	1.0
2	601-2670-303	RES 267 Ohm 1% 1/10w 0805	R11	I	1.0
2	601-0102-503	RES 1K Ohm 5% 1/10W 0805	R17,R18	I	2.0
2	601-0101-503	RES 100 Ohm 5% 1/10w 0805	R19-R22	I	4.0
2	601-0000-503	RES 0 Ohm 5% 1/10w 0805	R23	I	1.0
2	621-0011-016	IC, C&T F65545/B2-5 (24)	U1	I	1.0
2	631-0002-008	256k X 16 DRAM 70n	U2,U3	I	2.0
2	612-0245-002	IC, 74HCT245DW (SM)	U4	I	1.0
2	650-0032-002	SOCKET 32P AMP 822498-1 (28)	U5	I	1.0
2	612-0008-001	IC, 74HCT08 (SM)	U7	I	1.0
2	612-0004-001	IC, 74HCT04	U8	I	1.0
2	612-0373-002	IC, 74HCT373 (SM)	U9,U11	I	2.0
2	612-0074-001	IC, 74HCT74 (SM)	U12	I	1.0
2	612-0032-001	IC, 74HCT32	U13	I	1.0
2	220-0000-000	HC49 INSULATOR XTAL	Y1-INSTALL BEFORE XTAL	I	1.0
2	220-0032-001	XTAL-14.31818 (ABRACON) ABL-14.31818	Y1	I	1.0
2	400-0258-000C	PCB, MD-VGA REV.C		I	1.0

SUB-ASSEMBLY TOTAL: 0258-130-0000C ARLIN - 34 Items

1	0258-310-0000C	SUB ASSY MDVGA REV.C		F	1.0
2	999-9999-001	SPECIAL NOTES	05-08-97 MEB (NEW REVC)	I	1.0
2	201-0002-000	PLUG JUMPER 999-19-310-00-000000	J4=1-2	I	1.0
2	999-9999-001	SPECIAL NOTES	J7=OPEN	I	1.0
2	634-0002-015	IC, AT27C040-15JC [SM] (15)	U5 CS=4B00 \MDVGA\REL1218.BIN	I	1.0
2	500-0001-000	EJECTOR SCANBE S208-1 (W/O Roll pin)	STAMP: RED-MCM/BLUE-LPM 'MD-VGA'	I	1.0

05/18/01  
13:39:57

BOM for Manuals  
WinSystems, Inc.

PAGE 2

ASSM ITEM FROM: LPM-MDVGA-1M  
PARENT LOC FROM: <FIRST>

DEFAULT COMPONENT LOCATION: ARLIN

ASSM ITEM THRU: LPM-MDVGA-1M  
PARENT LOC THRU: <LAST>

LVL	ITEM KEY	ITEM DESCRIPTION	BOM COMMENT	ITEM TYPE	QTY REQUIRED
2	500-0002-000	ROLL PIN MS171492	ROLL PIN MS171492	I	1.0

SUB-ASSEMBLY TOTAL: 0258-310-0000C ARLIN - 6 Items

TOP ASSEMBLY TOTAL: LPM-MDVGA-1M ARLIN - 3 Items

REPORT RECAP

0 WARNING(S)

PARAMETER RECAP

PARAMETER KEY : 10 BOM with Ref. Desc.  
REPORT TITLE : BOM for Manuals

ASSM ITEM RANGE : LPM-MDVGA-1M THRU LPM-MDVGA-1M COSTING METHOD : A  
 PARENT LOC RANGE : <FIRST> THRU <LAST> QUANTITY TO EXPLODE : 1  
 PRODUCT KEY RANGE : <FIRST> THRU <LAST> USE SCRAP FACTOR (Y/N) : N  
 COMMODITY KEY RANGE : <FIRST> THRU <LAST> UPDATE INV STD COST : N  
 NO. LEVELS TO EXPLODE : 999  
 DEFAULT COMP LOC : ARLIN COLUMNS OF DESC TEXT : 42  
 BOM STATUS PRIORITY : A SHORT OR LONG (S/L) : S  
 PRINT ITEM DESC (Y/N) : Y

# **5** APPENDIX C

LPM/MCM-MDVGA Schematic Diagrams



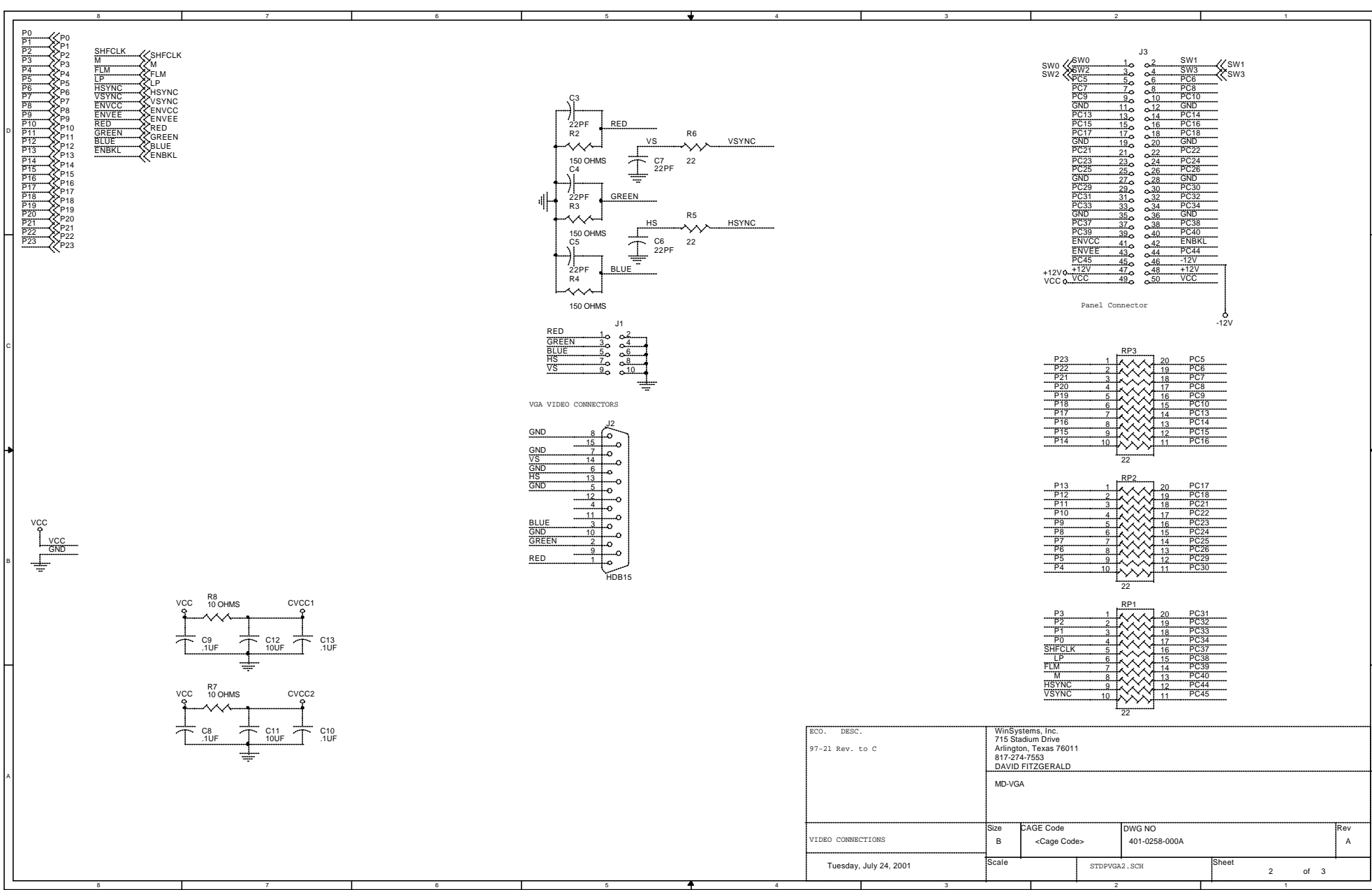

- P0 SHFCLK
- P1 M
- P2 FLM
- P3 LP
- P4 HSYNC
- P5 VSYNC
- P6 ENVCC
- P7 ENVEE
- P8 RED
- P9 GREEN
- P10 BLUE
- P11 ENBKL
- P12
- P13
- P14
- P15
- P16
- P17
- P18
- P19
- P20
- P21
- P22
- P23

- SW0 SW1
- SW2 SW3
- PC5 PC6
- PC7 PC8
- PC9 PC10
- GND GND
- PC13 PC14
- PC15 PC16
- PC17 PC18
- GND GND
- PC21 PC22
- PC23 PC24
- PC25 PC26
- GND GND
- PC29 PC30
- PC31 PC32
- PC33 PC34
- GND GND
- PC37 PC38
- PC39 PC40
- ENVCC ENBKL
- ENVEE PC44
- PC45 -12V
- +12V +12V
- VCC VCC

- Panel Connector
- P23 1
  - P22 2
  - P21 3
  - P20 4
  - P19 5
  - P18 6
  - P17 7
  - P16 8
  - P15 9
  - P14 10

- P13 1
- P12 2
- P11 3
- P10 4
- P9 5
- P8 6
- P7 7
- P6 8
- P5 9
- P4 10

- P3 1
- P2 2
- P1 3
- P0 4
- SHFCLK 5
- LP 6
- FLM 7
- M 8
- HSYNC 9
- VSYNC 10

ECO. DESC. 97-21 Rev. to C	WinSystems, Inc. 715 Stadium Drive Arlington, Texas 76011 817-274-7553 DAVID FITZGERALD		
	MD-VGA		
VIDEO CONNECTIONS	Size B	CAGE Code <Cage Code>	DWG NO 401-0258-000A
Tuesday, July 24, 2001	Scale	STDPVGA2.SCH	Sheet 2 of 3

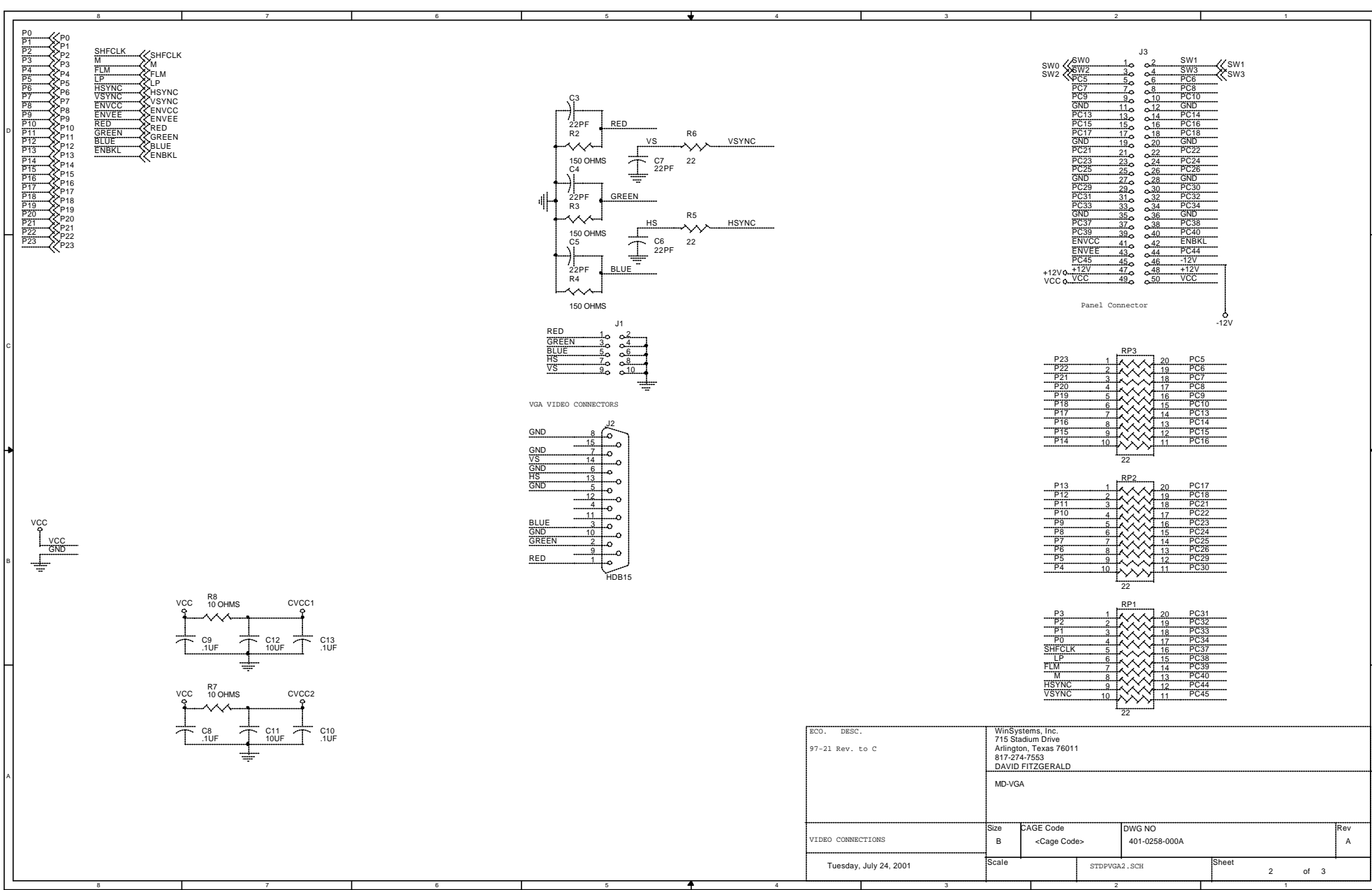

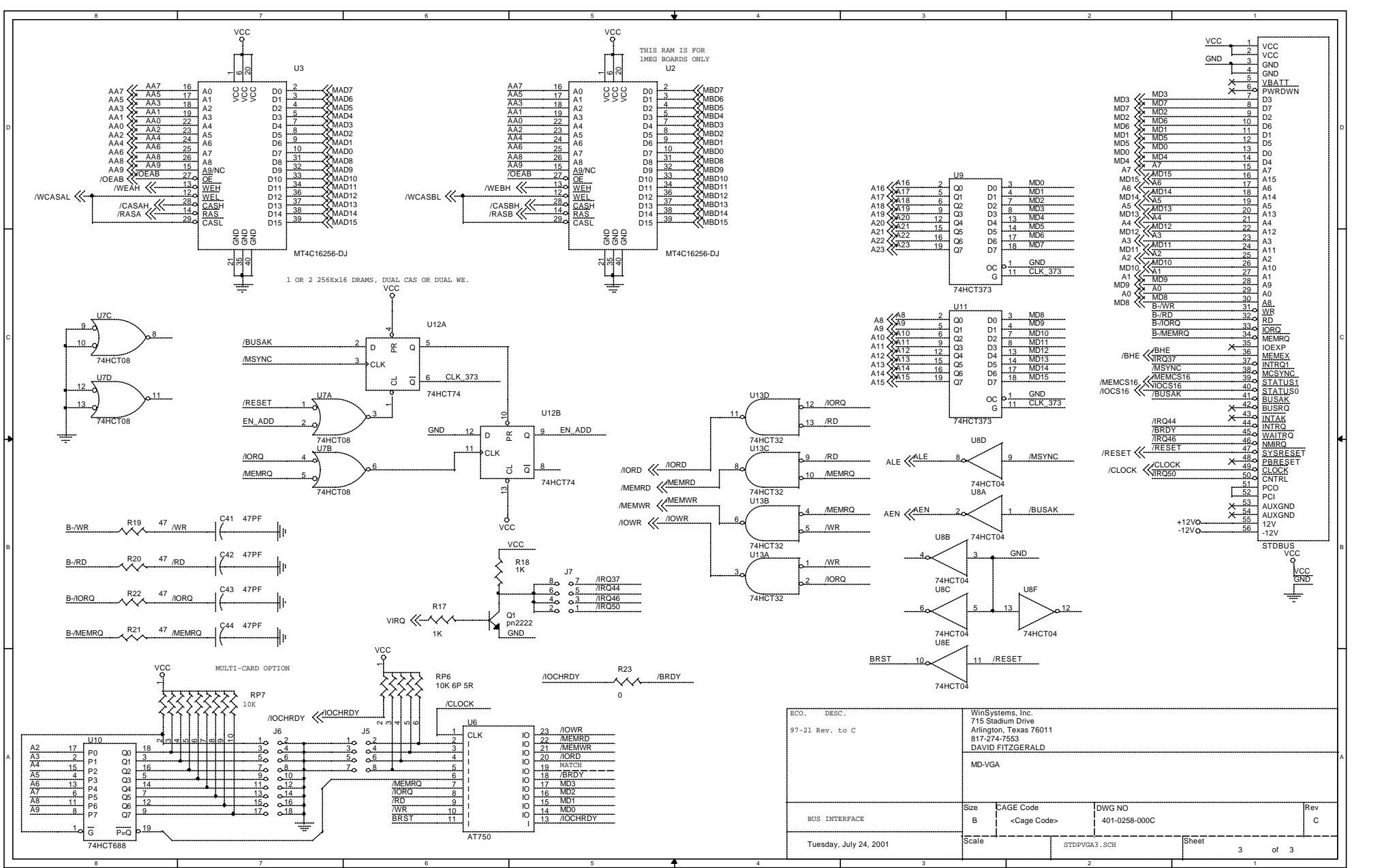

ECO.	DESC.	WinSystems, Inc. 715 Stadium Drive Arlington, Texas 76011 817-274-7553 DAVID FITZGERALD		
97-21 Rev. to C		MD-VGA		
BUS INTERFACE	Size B	CAGE Code <Cage Code>	DWG NO 401-0258-000C	Rev C
Tuesday, July 24, 2001	Scale	STDPVGA3.SCH	Sheet 3 of 3	



Telephone: 817-274-7553 . . Fax: 817-548-1358  
<http://www.winsystems.com> . . E-mail: [info@winsystems.com](mailto:info@winsystems.com)

## WARRANTY

WinSystems warrants that for a period of two (2) years from the date of shipment any Products and Software purchased or licensed hereunder which have been developed or manufactured by WinSystems shall be free of any material defects and shall perform substantially in accordance with WinSystems' specifications therefore. With respect to any Products or Software purchased or licensed hereunder which have been developed or manufactured by others, WinSystems shall transfer and assign to Customer any warranty of such manufacturer or developer held by WinSystems, provided that the warranty, if any, may be assigned. The sole obligation of WinSystems for any breach of warranty contained herein shall be, at its option, either (i) to repair or replace at its expense any materially defective Products or Software, or (ii) to take back such Products and Software and refund the Customer the purchase price and any license fees paid for the same. Customer shall pay all freight, duty, broker's fees, insurance changes and other fees and charges for the return of any Products or Software to WinSystems under this warranty. WinSystems shall pay freight and insurance charges for any repaired or replaced Products or Software thereafter delivered to Customer within the United States. All fees and costs for shipment outside of the United States shall be paid by Customer. The foregoing warranty shall not apply to any Products or Software which have been subject to abuse, misuse, vandalism, accidents, alteration, neglect, unauthorized repair or improper installations.

**THERE ARE NO WARRANTIES BY WINSYSTEMS EXCEPT AS STATED HEREIN. THERE ARE NO OTHER WARRANTIES EXPRESS OR IMPLIED INCLUDING, BUT NOT LIMITED TO, THE IMPLIED WARRANTIES OF MERCHANTABILITY AND FITNESS FOR A PARTICULAR PURPOSE, IN NO EVENT SHALL WINSYSTEMS BE LIABLE FOR CONSEQUENTIAL, INCIDENTAL, OR SPECIAL DAMAGES INCLUDING, BUT NOT LIMITED TO, DAMAGES FOR LOSS OF DATA, PROFITS OR GOODWILL. WINSYSTEMS' MAXIMUM LIABILITY FOR ANY BREACH OF THIS AGREEMENT OR OTHER CLAIM RELATED TO ANY PRODUCTS, SOFTWARE, OR THE SUBJECT MATTER HEREOF, SHALL NOT EXCEED THE PURCHASE PRICE OR LICENSE FEE PAID BY CUSTOMER TO WINSYSTEMS FOR THE PRODUCTS OR SOFTWARE OR PORTION THEREOF TO WHICH SUCH BREACH OR CLAIM PERTAINS.**

## WARRANTY SERVICE

All products returned to WinSystems must be assigned a Return Material Authorization (RMA) number. To obtain this number, please call or FAX WinSystems' factory in Arlington, Texas and provide the following information:

1. Description and quantity of the product(s) to be returned including its serial number.
2. Reason for the return.
3. Invoice number and date of purchase (if available), and original purchase order number.
4. Name, address, telephone and FAX number of the person making the request.
5. Do not debit WinSystems for the repair. WinSystems does not authorize debits.

After the RMA number is issued, please return the products promptly. Make sure the RMA number is visible on the outside of the shipping package.

The customer must send the product freight prepaid and insured. The product must be enclosed in an anti-static bag to protect it from damage caused by static electricity. Each bag must be completely sealed. Packing material must separate each unit returned and placed as a cushion between the unit(s) and the sides and top of the shipping container. WinSystems is not responsible for any damage to the product due to inadequate packaging or static electricity.