

OPERATIONS MANUAL PCM-NE2000-BNC

WinSystems reserves the right to make changes in the circuitry
and specifications at any time without notice.
© Copyright 1996 by WinSystems. All Rights Reserved.

REVISION HISTORY

P/N 403-254-000

ECO Number	Date Code	Rev Level
Originated	960814	A
98-07	981120	A1

TABLE OF CONTENTS

Section	Paragraph Title	Page
	Visual Index – Quick Reference	
1	General Information	1-1
	General Description	1-1
	Ethernet Overview	1-1
	Specifications	1-3
2	PCM-NE2000-BNC Technical Reference	2-1
	Introduction	2-1
	Bus Size Selection	2-2
	Jumpered vs. Jumperless Mode	2-3
	I/O Port Selection	2-4
	Interrupt Selection	2-5
	I/O vs. Shared Memory Mode	2-6
	Media Type Selection	2-6
	Boot ROM Selection	2-7
	Compatible vs. Enhanced Mode	2-7
	Status LEDs	2-8
	PlusCfg Configuration Utility Usage	2-8
	PC/104 Bus Pin Definitions	2-14
	Connector/Jumper Summary	2-15
APPENDIX A	DP83905 AT/LANTIC™ Controller Datasheet	
APPENDIX B	PCM-NE2000-BNC Schematic Diagram	
	Warranty and Repair Information	

TRADEMARKS

AT/LANTIC™ is a registered trademark of National Semiconductor Corporation.

Ethernet™ is a registered trademark of Xerox Corporation.

EtherCard PLUS™ and EtherCard PLUS 16™ are trademarks of Standard Microsystems Corporation.

IBM™, OS/2™, PC™, PC-AT™, PC-XT™ are registered trademarks of International Business Machines.

MS™, MS-DOS™, MS-Windows™ are registered trademarks of Microsoft Corporation.

Netware™ and Novell™ are registered trademarks of Novell Inc.

Visual Index – Quick Reference

For the convenience of the user, a copy of the Visual Index has been provided with direct links to connector and jumper configuration data.

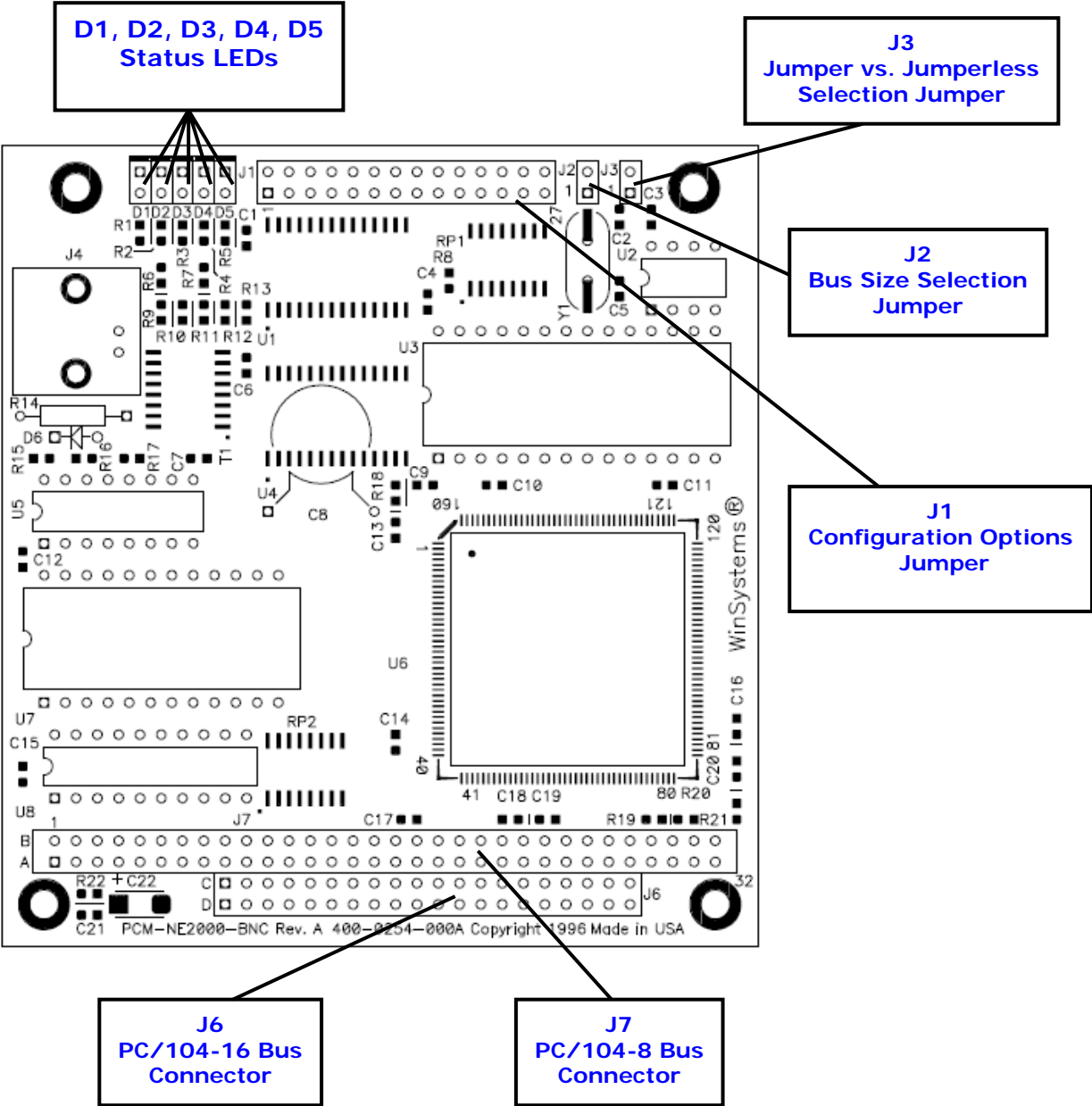

1 General Information

1.1 FEATURES

- NE2000 Compatible PC/104 Ethernet Controller
- Uses National AT/LANTIC™ High Integration Controller
- 802.3 Ethernet Compliant with 10BASE2 support
- +5 Volt only Operation
- Can be configured via jumpers or jumperless through configuration software
- Onboard EEPROM stores configuration information
- Boot ROM socket for Diskless Network access

1.2 General Description

The PCM-NE2000-BNC is a PC/104 Ethernet adapter which is software compatible with the Novell NE2000 ISA bus Ethernet card. This compatibility allows the use of a wealth of driver software existing for the NE2000. Nearly all Network software vendors and real-time O/S vendors support the NE2000 architecture directly or with drivers they supply themselves. Support includes Netware, Lantastic, Windows for Work Groups, Windows 95, QNX, and a host of others.

The PCM-NE2000-BNC can be configured either by using the onboard jumper block or can be used in a software-configured “jumperless” mode.

The supplied utility/driver diskette includes the configuration utility as well as ODI, NDIS, and Packet drivers.

1.3 Ethernet Overview

Ethernet is the most widely installed LAN standard for connecting personal computers and workstations with information resources, servers, and other peripherals.

The 10MBS Ethernet CSMA/CD (Carrier Sense Multiple Access with Collision Detection) protocol defines how a node will gain access to the network. The node first monitors the media to ensure that no transmissions are in progress (Carrier Sense). The node may then decide to transmit (Multiple Access). If more than one node decides to transmit simultaneously, then a collision will occur. All nodes will be able to detect this condition (Collision Detection), stop their transmissions, and retry after a random period of time.

Ethernet physical layer specifications include 10BASE5 which defines the use of thick, double-shielded coax in a bus topology. 10BASE2 defines the use of thin coax in a bus configuration. 10BASE-T defines the use of unshielded twisted pair cable in a star configuration. The table on the following page contrasts the three most common Ethernet media types.

Parameter	10BASE5	10BASE2	10BASE-T
Designator	Thick Coax	Thin Coax	Twisted-Pair
Segment Length	500 Meters	185 Meters	100 Meters Nominal
Topology	BUS (Multi-Point)	BUS (Multi-Point)	Star (point-to-point)
Cable Type	0.4" Diam. 50 OHM Double Shielded COAX (RG11)	0.2" Diam. 50 OHM Single Shield COAX (RG58)	24 Guage 100 OHM Twisted-Pair
Connection	Precision TAP	BNC "T"	8-pin RJ-45

1.3.1 National DP83905 AT/LANTIC™ Controller

The PCM-NE2000-BNC incorporates the National Semiconductor DP83905 AT/LANTIC™ Local Area Network Twisted-Pair Interface Controller (See complete datasheet reprint in Appendix C).

The AT/LANTIC™ Controller is a CMOS VLSI device used in the implementation of CSMA/CD local area networks. Unique to the AT/LANTIC™ is the integration of the entire bus interface for PC-AT ISA and PC/104 bus systems. Hardware and software selectable options allow the AT/LANTIC™ to be configured as software compatible to either an NE2000 or an EtherCard PLUS 16™. The single supported network interface on the PCM-NE2000-BNC is 10BASE2. Support for 10BASE5 or 10BASE-T is provided on an alternate version of the board the PCM-NE2000. The AT/LANTIC™ Chip provides the Ethernet Media Access Control (MAC), Encode-Decode (ENDEC) with an AUI interface, and 10BASE-T transceiver functions in accordance with the IEEE 802.3 standards.

This functional block incorporates the receiver, transmitter, collision, heartbeat, loop-back, jabber, and link integrity blocks as defined in the standard. The transceiver when combined with the equalization resistors, transmit/receive filters, and pulse transformers provide a complete physical interface from the AT/LANTIC™ Controller's ENDEC module and the twisted pair medium.

The integrated ENDEC module allows the Manchester encoding and decoding via a differential transceiver and phase lock loop decoder at 10 Mbit/sec. Also included are a collision detect translator and diagnostic loopback capability. The ENDEC module interfaces directly to the transceiver module, and also provides a fully IEEE compliant AUI (Attachment Unit Interface) for connection to other media transceivers.

The Media Access Control (MAC) function is provided by the Network Interface Control module (NIC) which provides simple and efficient packet transmission and reception control by means of off-board memory which can be accessed either through an I/O port or mapped into the system memory map.

1.4 SPECIFICATIONS

1.4.1 Electrical

Bus Interface: PCM-NE2000-BNC-8 PC/104 8-Bit stackthrough
 PCM-NE2000-BNC-16 PC/104 16-Bit stackthrough

Power Requirements: +5V +/-5% at 350mA. typ.

1.4.2 Mechanical

Dimensions: 3.6" X 3.8" X 0.6"

PC Board : FR4 Epoxy glass with 2 signal layers and 2 power planes with screened component legend and plated through holes.

Jumpers : 0.025" square posts on 0.10" centers.

Connectors : 10BASE2 - Female BNC

1.4.3 Environmental

Operating Temperature : -40° to +85° C

Non-Condensing relative Humidity : 5% to 95%

2

PCM-NE2000-BNC Technical Reference

2.1 Introduction

This section of the manual is intended to provide sufficient information regarding the configuration and usage of the PCM-NE2000-BNC PC/104 Ethernet module. WinSystems maintains a Technical Support Group to help answer questions regarding the configuration and usage of the board. For answers to questions not adequately addressed in this manual contact Technical Support at (817) 274-7553 between 8AM and 5PM Central Time.

The PCM-NE2000-BNC is designed to offer flexible, high-performance, networking capability for the PC/104 bus. It is available with either an 8-bit or 16-bit interface for maximum flexibility and performance.

The PCM-NE2000-BNC uses the National DP83905 high integration Ethernet Controller described in section 1. A complete datasheet reprint for the AT/LANTIC™ DP83905 is reprinted in APPENDIX C for users requiring detailed information.

The PCM-NE2000-BNC supports direct connection to 10BASE2 thin Ethernet networks via its BNC connector at J4.

An onboard EEPROM holds the Ethernet Address and optional configuration information. This allows for “jumperless” configuration using software to configure the board for its operating mode, media type, I/O address, interrupt, etc. A software utility “PlusCfg” is provided to configure the module. Refer to Section 2.11 for use of the configuration program. The PCM-NE2000-BNC also supports “jumpered” configuration usable for non-DOS applications where the configuration utility is not usable.

Probably the PCM-NE2000-BNC's most attractive feature is the software compatibility with the industry standard NE2000 architecture. This compatibility virtually assures the availability of supporting software and drivers for everything from Netware to Windows 95. Although a number of drivers are provided with the PCM-NE2000-BNC, on the driver/utility diskette, the board is fully compatible with any software or drivers written for the NE2000 architecture.

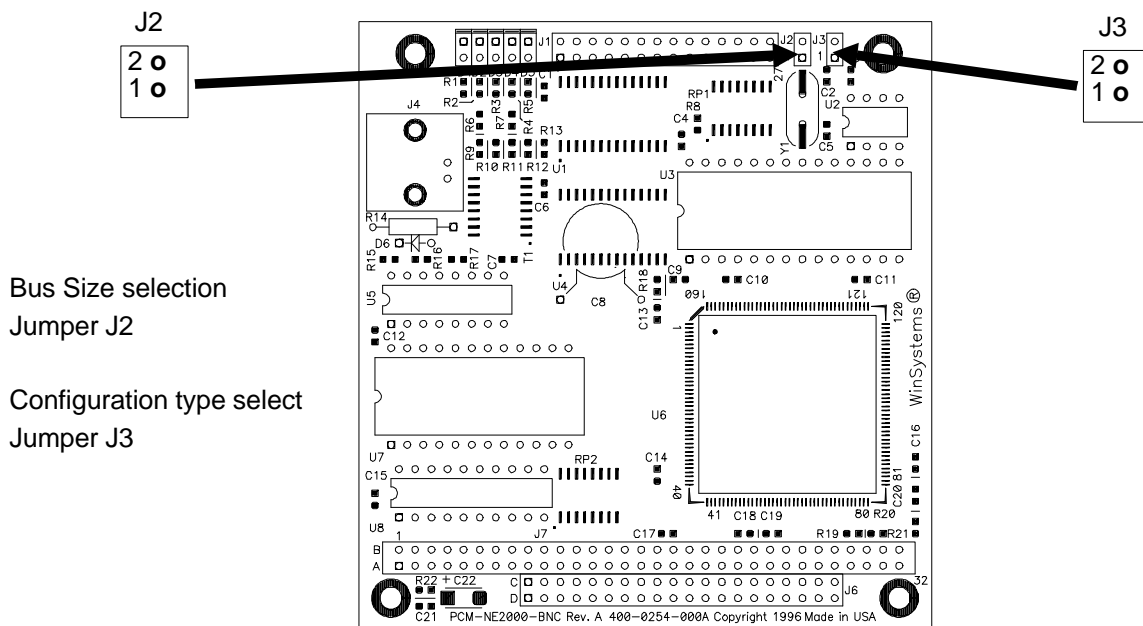

2.2 Bus Size Selection

The PCM-NE2000-BNC is supplied in either of 2 models; the PCM-NE2000-BNC-8 is supplied for 8-bit PC/104 usage and the PCM-NE2000-BNC-16 is supplied for use with 16-bit PC/104 systems. The jumper block at J2 should be configured as shown below for the proper board type.

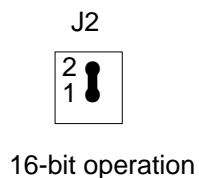
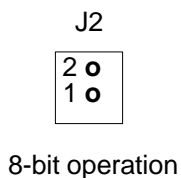

Note : The PCM-NE2000-BNC-16 can be used in an 8-bit mode by simply setting the J2 jumper to the 8-bit mode. However, the PCM-NE2000-BNC-8 should never be jumpered for 16-bit mode or improper operation will result.

2.3 Jumpered vs. Jumperless Mode

The PCM-NE2000-BNC can be configured either through the jumper block at J1 (detailed in later sections) or via the configuration information stored in the onboard EEPROM. The source for the configuration information is made at jumper J3 as shown below:

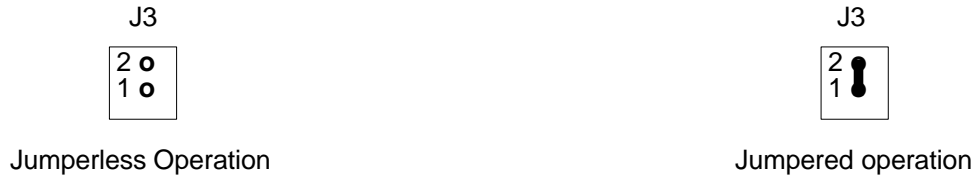

NOTE : The choice of "jumpered" or "jumperless" is totally exclusive. This means that if "jumperless" mode is selected all of the jumpers on J1 are ignored and the configuration information comes totally from the EEPROM. Similarly, if "jumpered" mode is selected the information in the EEPROM (Except for the Ethernet Address) is ignored.

The following sections detail the J1 jumpering when the "jumpered" mode is selected.

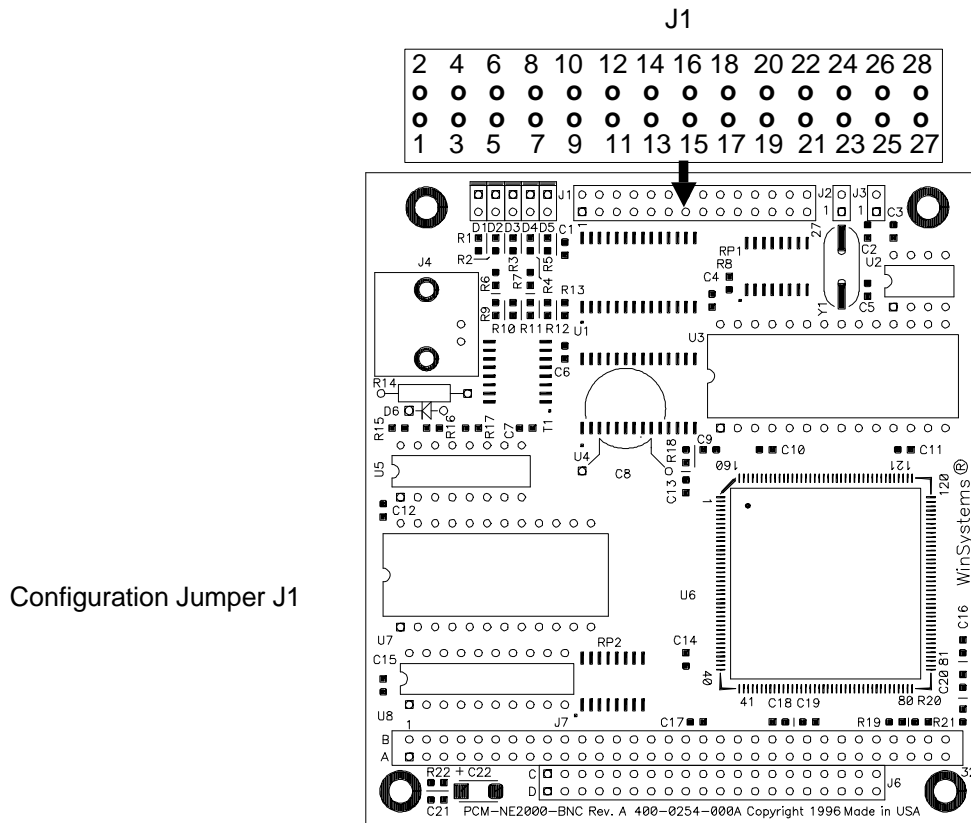

2.4 I/O Port Selection

The PCM-NE2000-BNC uses 32 consecutive I/O addresses in the 80X86 I/O space. The base address is selected using three pins on the J1 configuration jumper. The choices available are :

- 240H
- 280H
- 2C0H
- 300H
- 320H
- 340H
- 360H

The proper jumpering for each of these choices is shown in the following illustrations.

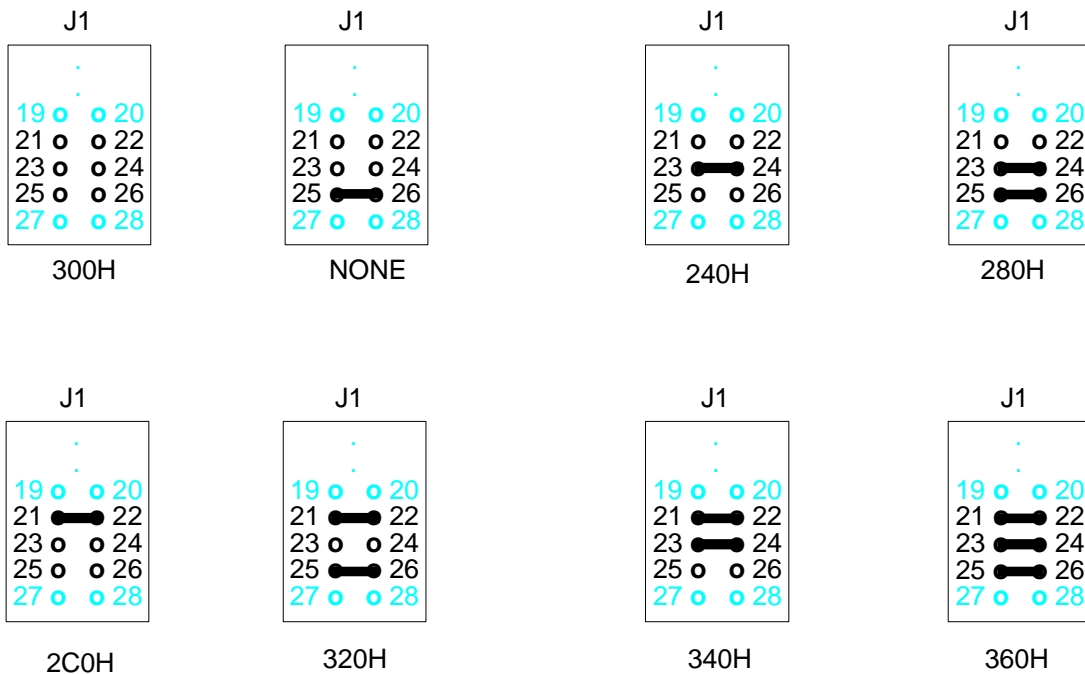

2.5 Interrupt Selection

The PCM-NE2000-BNC needs an interrupt line for signaling various conditions to the software driver. There are 8 possible choices (4 on the 8-bit version) as shown here :

- IRQ 3
- IRQ 4
- IRQ 5
- IRQ 9
- IRQ 10
- IRQ 11
- IRQ 12
- IRQ 15

The proper jumpering for the three relevant jumper positions corresponding to the available interrupt choices are shown here :

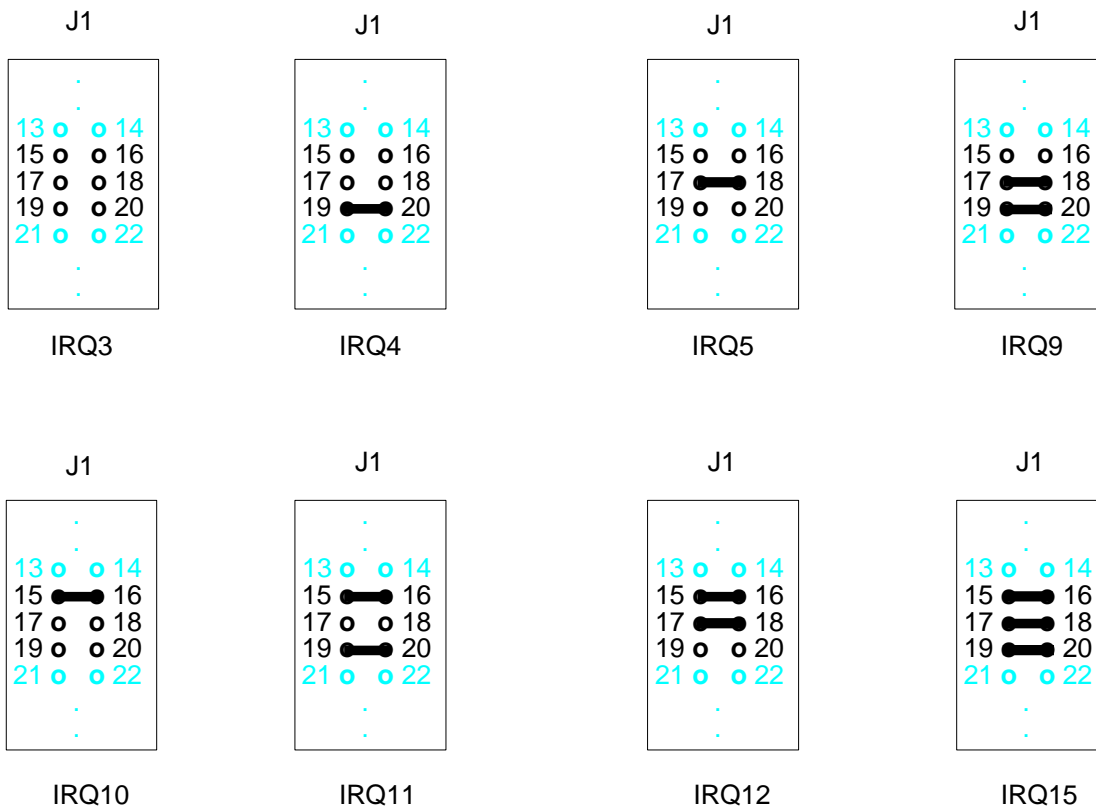

2.6 I/O vs. Shared Memory Mode

The buffer RAM within the PCM-NE2000-BNC can be accessed in either of 2 ways. In the typical NE2000 compatible mode, the RAM is accessed through the NIC via I/O ports. An alternate access scheme is available using the shared memory mode. In this mode the board is software compatible with the WD8013EBT from Standard Microsystems (formerly Western Digital). In this mode a 32K window in the PC adapter space is used to access packet memory. The address of this window is controlled by the driver. For NE2000 compatibility the I/O mode is selected. The jumpering for each of the access modes is shown below :

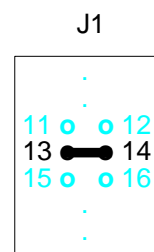
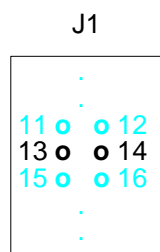

2.7 Media Type Selection

The media type is also jumper selectable via 2 pins on J1. The only supported media type on the PCM-NE2000-BNC is:

Thin Ethernet (10BASE2)

And is selected as shown below.

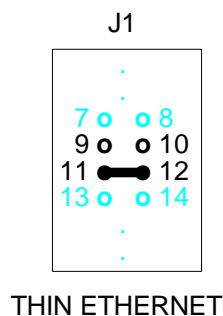

2.8 Boot ROM Selection

The PCM-NE2000-BNC supports the use of the remote boot feature available with Novell and some other operating systems by providing a BIOS Extension boot ROM socket. A user supplied ROM may be installed into U3. The ROM should be a 32K X 8 device of 150nS or faster (type 27C256). The address of the ROM can be selected via a set of jumpers on J1. The addresses available are :

C0000H
C8000H
D0000H
D8000H

The correct jumpering for each of the supported addresses is shown here :

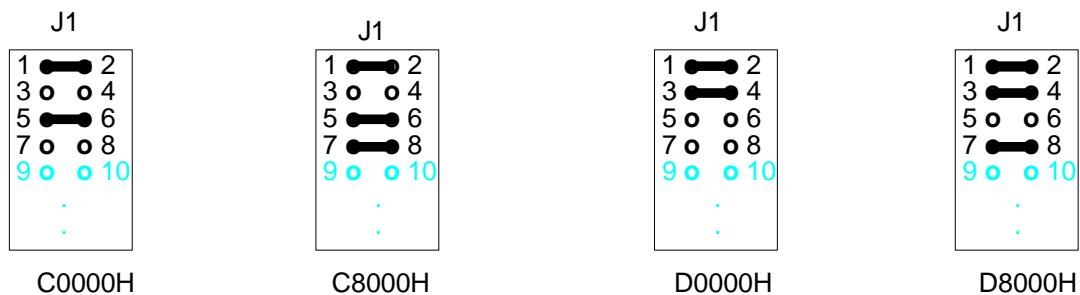

Note : Jumper combinations other than those shown will not result in proper recognition of the ROM. With no jumpers installed the ROM is disabled.

2.9 Compatible Vs Enhanced Mode

The PCM-NE2000-BNC uses two 32K byte buffer RAMs on board. In compatible mode only 8K of each RAM (total of 8K or 16K depending on 8-bit or 16-bit mode) is accessible to the driver. When the non-compatible mode is chosen the full 32K is available from each RAM. This Enhanced mode is generally supported by the supplied AT/LANTIC drivers but may not be usable with generic NE2000 software or drivers. When in doubt, choose the compatible mode.

The J1 jumpering for the compatible and enhanced modes are shown here :



2.10 Status LEDs

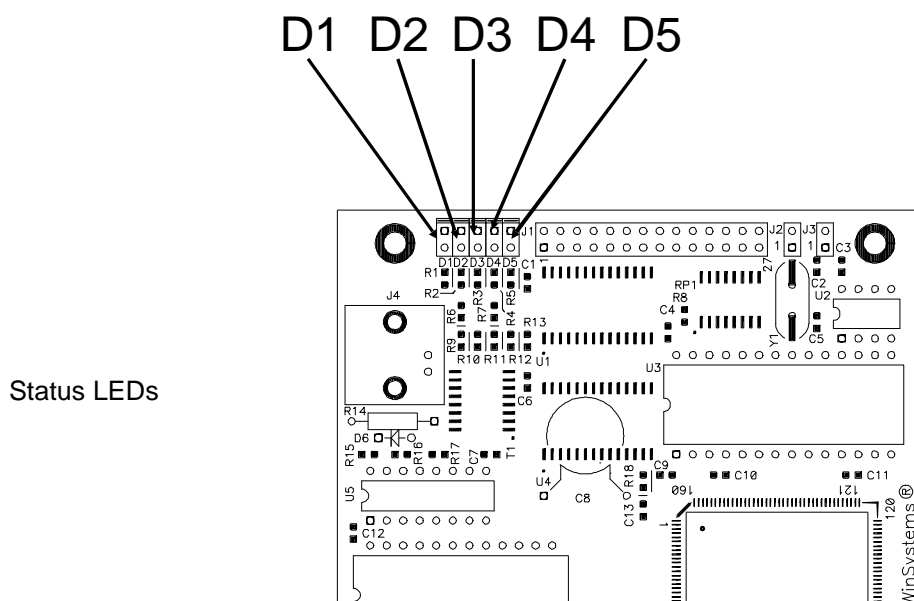

There are four LEDs installed on the PCM-NE2000-BNC. These status LEDs give visual indication as to the status of the board. The color, location, and general description of each of the status LEDs follows :

- D1 GREEN - Transmit activity
- D2 GREEN - Receive activity (All packets on network)
- D3 RED - Collision
- D4 NOT INSTALLED
- D5 NOT INSTALLED

2.11 PlusCfg Configuration Utility

When the "jumperless mode is selected (See Section 2.3), the configuration is made via software which is then saved to the onboard EEPROM. PLUSCFG.EXE along with MESSAGE.MSG can be run from the provided floppy or can be copied to a hard disk. From the DOS command line PLUSCFG.EXE is executed by typing :

```
pluscfg [Enter]
```

The configuration program will load and display the basic menu and configuration screen. If any AT/LANTIC™, or NE2000 adapters are recognized they will be displayed in a window on the right side of the screen as shown on the following page:

WinSystems Thick/Thin/TPI August 20, 1993 11:34PM	PLUSCFG V1.17	AT/LANTIC Configuration Software								
<p style="text-align: center;">CONFIGURATION</p> Configure New Adapter Display/Change Adapter Configuration Diagnostics Quit and Return to DOS	<p style="text-align: center;">AT/LANTIC ADAPTERS</p> <table style="width: 100%; border-collapse: collapse;"> <thead> <tr> <th style="text-align: left;">I/O Port</th> <th style="text-align: left;">Mode</th> <th style="text-align: left;">IRQ</th> </tr> </thead> <tbody> <tr> <td>0x320</td> <td>I/O Port</td> <td>10</td> </tr> <tr> <td>0x360</td> <td>I/O Port</td> <td>5</td> </tr> </tbody> </table>	I/O Port	Mode	IRQ	0x320	I/O Port	10	0x360	I/O Port	5
I/O Port	Mode	IRQ								
0x320	I/O Port	10								
0x360	I/O Port	5								
***** Make Selection using arrow keys and <enter> ***** ***** Scroll through options using <tab> *****										

From the main menu choose the desired function. Each of the main menu choices will be discussed in the following sections.

2.11.1 **Configure New Adapter**

This screen is used to configure an installed adapter that is not present in the window on the right side of the screen. Typically this would be a board that had its I/O port set to "None".

Two choices are provided to configure the new adapter.

The "Configure New Adapter Automatically" will search out an unconfigured adapter if present, survey the system, and make automatic choices for I/O address and interrupts for what it believes are free for use. The system will then display a series of configuration options to the user. These options include :

- Adapter Architecture - I/O Port or Shared Memory
- Select Cable Interface - Thin Ethernet or Thick Ethernet or 10BASE-T

The second prompt will only be presented if there is no active cable attached or the program is unable to determine the media type.

WinSystems Thick/Thin/TPI August 20, 1993 11:34PM	PLUSCFG V1.17	AT/LANTIC Configuration Software									
<div style="border: 1px solid black; padding: 10px; margin: 10px auto; width: 80%;"> <p style="text-align: center; margin: 0;">CONFIGURATION</p> <div style="border: 1px solid black; padding: 5px; margin: 5px auto; width: 80%;"> <p style="text-align: center; margin: 0;">CONFIGURE NEW ADAPTER</p> <p style="margin: 5px 0;">Configure New Adapter Automatically</p> <p style="margin: 5px 0;">Configure New Adapter Manually</p> <p style="margin: 5px 0;">Return to previous menu</p> </div> </div>		<p style="text-align: center; margin: 0;">AT/LANTIC ADAPTERS</p> <table style="width: 100%; border-collapse: collapse;"> <thead> <tr> <th style="text-align: left; width: 33%;">I/O Port</th> <th style="text-align: left; width: 33%;">Mode</th> <th style="text-align: left; width: 33%;">IRQ</th> </tr> </thead> <tbody> <tr> <td>0x320</td> <td>I/O Port</td> <td>10</td> </tr> <tr> <td>_____</td> <td></td> <td></td> </tr> </tbody> </table>	I/O Port	Mode	IRQ	0x320	I/O Port	10	_____		
I/O Port	Mode	IRQ									
0x320	I/O Port	10									

<p>***** Make Selection using arrow keys and <enter> *****</p> <p>***** Scroll through options using <tab> *****</p>											

The "Configure New Adapter Manually" presents a screen similar to the one shown below :

WinSystems Thick/Thin/TPI August 20, 1993 11:34PM	PLUSCFG V1.17	AT/LANTIC Configuration Software												
<p style="text-align: center; margin: 0;">CONFIGURATION</p>		<p style="text-align: center; margin: 0;">AT/LANTIC ADAPTERS</p>												
<div style="border: 1px solid black; padding: 10px; margin: 10px auto; width: 90%;"> <p style="text-align: center; margin: 0;">CONFIGURE NEW ADAPTER MANUALLY</p> <table style="width: 100%; border-collapse: collapse;"> <tr> <td style="width: 60%;">Novell Configuration</td> <td>- None</td> </tr> <tr> <td>I/O Base Address</td> <td>- 0x240</td> </tr> <tr> <td>Interrupt assignment</td> <td>- IRQ3</td> </tr> <tr> <td>Physical Media</td> <td>- Thin Ethernet</td> </tr> <tr> <td>Adapter Architecture</td> <td>- I/O Port</td> </tr> <tr> <td>Boot Prom</td> <td>- No Boot Prom</td> </tr> </table> <p style="margin: 5px 0;">Advanced Configuration Options</p> <p style="margin: 5px 0;">Temporarily Change Configuration</p> <p style="margin: 5px 0;">Save Configuration</p> <p style="margin: 5px 0;">Return to previous menu</p> </div>			Novell Configuration	- None	I/O Base Address	- 0x240	Interrupt assignment	- IRQ3	Physical Media	- Thin Ethernet	Adapter Architecture	- I/O Port	Boot Prom	- No Boot Prom
Novell Configuration	- None													
I/O Base Address	- 0x240													
Interrupt assignment	- IRQ3													
Physical Media	- Thin Ethernet													
Adapter Architecture	- I/O Port													
Boot Prom	- No Boot Prom													
<p>***** Make Selection using arrow keys and <enter> *****</p> <p>***** Scroll through options using <tab> *****</p>														

Use the "up" and "down" arrow keys and the "tab" key to change the displayed configuration to what is desired and then select "Save Configuration" to program the EEPROM with the selected choices.

Note: PLUSCFG will not allow selection of I/O ports, interrupts, or memory addresses that it believes are being used by other hardware in the system. If PLUSCFG refuses to allow a desired selection for what you know are valid choices, it will be necessary to use the "jumpered" mode described earlier, for configuration.

2.11.2 Display/Change Adapter Configuration

This option of the main menu presents the same screen as shown for the "Configure New Adapter Manually". Use the "up" and "down" arrow keys and the "tab" key to alter the configuration as desired and then select "Save Configuration" to program the EEPROM with the new information.

Note: PLUSCFG will not allow selection of I/O ports, interrupts, or memory addresses that it believes are being used by other hardware in the system. If PLUSCFG refuses to allow a desired selection for what you know are valid choices, it will be necessary to use the "jumpered" mode described earlier, for configuration.

2.11.3 Diagnostics

This third choice from the main menu allows the selection from the diagnostics sub menu as shown in this screen below :

WinSystems Thick/Thin/TPI August 20, 1993 11:34PM	PLUSCFG V1.17	AT/LANTIC Configuration Software															
<table border="1" style="width: 80%; margin: auto; border-collapse: collapse;"> <tr> <td style="text-align: center; padding: 5px;"> CONFIGURATION </td> </tr> <tr> <td style="text-align: center; padding: 5px;"> INITIALIZATION AND DIAGNOSTICS </td> </tr> <tr> <td style="padding: 5px;"> Adapter Initialization & disagnostics Advanced Network Diagnostics </td> </tr> <tr> <td style="padding: 5px;"> Return to previous menu </td> </tr> </table>	CONFIGURATION	INITIALIZATION AND DIAGNOSTICS	Adapter Initialization & disagnostics Advanced Network Diagnostics	Return to previous menu	<table border="1" style="width: 100%; border-collapse: collapse;"> <tr> <th colspan="3" style="text-align: center; padding: 5px;">AT/LANTIC ADAPTERS</th> </tr> <tr> <th style="text-align: left; padding: 5px;">I/O Port</th> <th style="text-align: left; padding: 5px;">Mode</th> <th style="text-align: left; padding: 5px;">IRQ</th> </tr> <tr> <td style="padding: 5px;">0x320</td> <td style="padding: 5px;">I/O Port</td> <td style="padding: 5px;">10</td> </tr> <tr> <td style="padding: 5px;">0x360</td> <td style="padding: 5px;">I/O Port</td> <td style="padding: 5px;">5</td> </tr> </table>	AT/LANTIC ADAPTERS			I/O Port	Mode	IRQ	0x320	I/O Port	10	0x360	I/O Port	5
CONFIGURATION																	
INITIALIZATION AND DIAGNOSTICS																	
Adapter Initialization & disagnostics Advanced Network Diagnostics																	
Return to previous menu																	
AT/LANTIC ADAPTERS																	
I/O Port	Mode	IRQ															
0x320	I/O Port	10															
0x360	I/O Port	5															
***** Make Selection using arrow keys and <enter> ***** ***** Scroll through options using <tab> *****																	

2.11.4 Adapter Initialization & Diagnostics

This choice initializes the selected adapter and confirms I/O address, interrupt, media type, etc. The adapter should be connected to the network cable at this time. A sample screen is shown below :

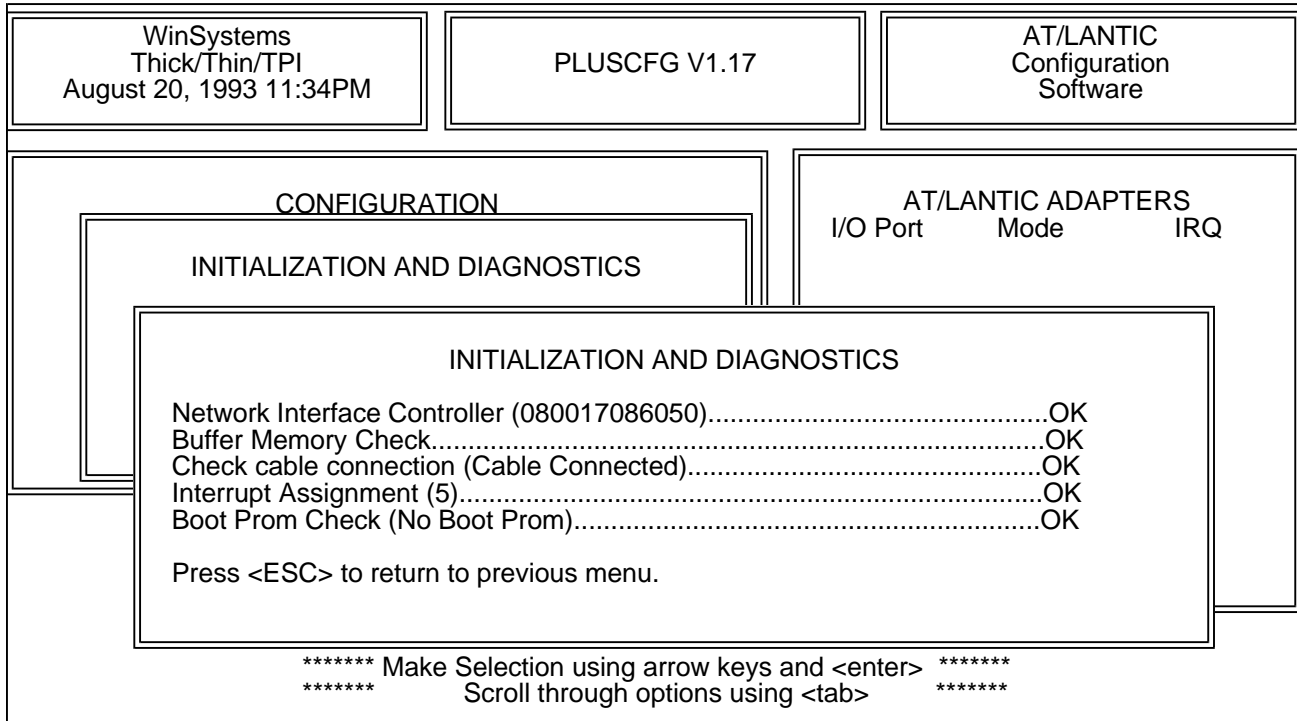

NOTE : The Initialization & Diagnostics must be run and pass before any of the Advanced diagnostics can be executed.

2.11.5 Advanced Network Diagnostics

The Advanced Network Diagnostics menu is shown on the following page.

Three choices are provided for Advanced Network Diagnostics.

2.11.6 Setup as a Master Station.

This enables the board under test to be set up as the Master. The master will initiate testing. The Slave must be enabled prior to starting the Master.

The system will then request a packet repetition length and after entered will begin the test.

WinSystems Thick/Thin/TPI August 20, 1993 11:34PM	PLUSCFG V1.17	AT/LANTIC Configuration Software									
<div style="border: 1px solid black; padding: 5px; margin: 5px auto; width: 80%;"> <p style="text-align: center; margin: 0;">CONFIGURATION</p> <div style="border: 1px solid black; padding: 5px; margin: 5px auto; width: 80%;"> <p style="text-align: center; margin: 0;">INITIALIZATION AND DIAGNOSTICS</p> <div style="border: 1px solid black; padding: 5px; margin: 5px auto; width: 80%;"> <p style="text-align: center; margin: 0;">ADVANCED NETWORK DIAGNOSTICS</p> <p style="margin: 5px 0;">Set up as a master station..</p> <p style="margin: 5px 0;">Setup as a slave station.</p> <p style="margin: 5px 0;">Show packets on network.</p> <p style="margin: 5px 0;">Return to previous menu</p> </div> </div> </div>		<p style="text-align: center; margin: 0;">AT/LANTIC ADAPTERS</p> <table style="width: 100%; border-collapse: collapse;"> <thead> <tr> <th style="text-align: left;">I/O Port</th> <th style="text-align: left;">Mode</th> <th style="text-align: left;">IRQ</th> </tr> </thead> <tbody> <tr> <td>0x320</td> <td>I/O Port</td> <td>10</td> </tr> <tr> <td>0x360</td> <td>I/O Port</td> <td>5</td> </tr> </tbody> </table>	I/O Port	Mode	IRQ	0x320	I/O Port	10	0x360	I/O Port	5
I/O Port	Mode	IRQ									
0x320	I/O Port	10									
0x360	I/O Port	5									
<p>***** Make Selection using arrow keys and <enter> *****</p> <p>***** Scroll through options using <tab> *****</p>											

2.11.7 Set up as Slave Station.

This choice should be made for a known good board. It will echo back across the network all packets initiated by the Master.

2.11.8 Show Packets On Network

This option displays in HEX and ASCII packets as they are received from the network. A sample screen is shown below :

WinSystems Thick/Thin/TPI August 20, 1993 11:34PM	PLUSCFG V1.17	AT/LANTIC Configuration Software		
<p style="text-align: center; margin: 0;">RECEIVED PACKET CONTENTS</p> <p style="margin: 5px 0;">Received Status : 01 Next Pointer : 54 Receiver Length : 1493</p> <p style="margin: 5px 0;">Destination 0040F698A3E6 Source : 0040F6988448</p> <p style="margin: 5px 0;">Length/Type : 05C3 Hex HW CRC : D703A649 SW CRC : NORMAL</p> <table style="width: 100%; border-collapse: collapse; margin-top: 10px;"> <tr> <td style="width: 50%; vertical-align: top;"> <p>0450 98 7D D0 40 03 00 00 00 01 00 00 00 00 01 04</p> <p>0460 51 33 33 87 02 01 00 00 00 04 00 20 44 6F 63 2D</p> <p>0470 06 00 F0 76 41 47 44 53 54 4D 00 00 00 40 E1 7A</p> <p>0480 74 BF 05 00 02 77 4D 44 54 47 53 00 04 00 0C 77</p> <p>0490 41 43 50 52 0E 00 14 77 41 43 44 49 4E 4F 50 52</p> <p>04A0 53 54 55 58 4F 47 0E 00 26 77 41 43 44 49 4E 4F</p> <p>04B0 50 52 53 54 55 58 4D 47 0C 00 38 77 49 54 45 4D</p> <p>04C0 20 4B 45 59 0C 00 54 77 56 41 4C 49 44 20 54 52</p> <p>04D0 23 23 23 59 0C 00 54 77 56 41 4C 49 44 20 54 53</p> <p>04E0 41 4E 53 3A 07 00 64 77 23 23 23 2C 23 23 23 52</p> </td> <td style="width: 50%; vertical-align: top;"> <p>..}.@.....</p> <p>Q33.....(Doc-</p> <p>..vAGDSTM...@.z</p> <p>t...wMDTGS...w</p> <p>ACPR...wACDINO</p> <p>STUXMG..&aACDINO</p> <p>PRSTUXMG..8wiTEM</p> <p>KEY :..Hw###,</p> <p>###Y...TwALID.TR</p> <p>ANS:...dw###,###R</p> </td> </tr> </table> <p style="text-align: center; margin-top: 10px;">Press <ESC> when finished examining receive packet</p>			<p>0450 98 7D D0 40 03 00 00 00 01 00 00 00 00 01 04</p> <p>0460 51 33 33 87 02 01 00 00 00 04 00 20 44 6F 63 2D</p> <p>0470 06 00 F0 76 41 47 44 53 54 4D 00 00 00 40 E1 7A</p> <p>0480 74 BF 05 00 02 77 4D 44 54 47 53 00 04 00 0C 77</p> <p>0490 41 43 50 52 0E 00 14 77 41 43 44 49 4E 4F 50 52</p> <p>04A0 53 54 55 58 4F 47 0E 00 26 77 41 43 44 49 4E 4F</p> <p>04B0 50 52 53 54 55 58 4D 47 0C 00 38 77 49 54 45 4D</p> <p>04C0 20 4B 45 59 0C 00 54 77 56 41 4C 49 44 20 54 52</p> <p>04D0 23 23 23 59 0C 00 54 77 56 41 4C 49 44 20 54 53</p> <p>04E0 41 4E 53 3A 07 00 64 77 23 23 23 2C 23 23 23 52</p>	<p>..}.@.....</p> <p>Q33.....(Doc-</p> <p>..vAGDSTM...@.z</p> <p>t...wMDTGS...w</p> <p>ACPR...wACDINO</p> <p>STUXMG..&aACDINO</p> <p>PRSTUXMG..8wiTEM</p> <p>KEY :..Hw###,</p> <p>###Y...TwALID.TR</p> <p>ANS:...dw###,###R</p>
<p>0450 98 7D D0 40 03 00 00 00 01 00 00 00 00 01 04</p> <p>0460 51 33 33 87 02 01 00 00 00 04 00 20 44 6F 63 2D</p> <p>0470 06 00 F0 76 41 47 44 53 54 4D 00 00 00 40 E1 7A</p> <p>0480 74 BF 05 00 02 77 4D 44 54 47 53 00 04 00 0C 77</p> <p>0490 41 43 50 52 0E 00 14 77 41 43 44 49 4E 4F 50 52</p> <p>04A0 53 54 55 58 4F 47 0E 00 26 77 41 43 44 49 4E 4F</p> <p>04B0 50 52 53 54 55 58 4D 47 0C 00 38 77 49 54 45 4D</p> <p>04C0 20 4B 45 59 0C 00 54 77 56 41 4C 49 44 20 54 52</p> <p>04D0 23 23 23 59 0C 00 54 77 56 41 4C 49 44 20 54 53</p> <p>04E0 41 4E 53 3A 07 00 64 77 23 23 23 2C 23 23 23 52</p>	<p>..}.@.....</p> <p>Q33.....(Doc-</p> <p>..vAGDSTM...@.z</p> <p>t...wMDTGS...w</p> <p>ACPR...wACDINO</p> <p>STUXMG..&aACDINO</p> <p>PRSTUXMG..8wiTEM</p> <p>KEY :..Hw###,</p> <p>###Y...TwALID.TR</p> <p>ANS:...dw###,###R</p>			

2.11.9 Quit and return to DOS

This main menu option exits PlusCfg and returns you to the DOS prompt.

2.12 PC/104 Bus Pin Definitions

The J6 and J7 PC/104 bus connector pin definitions are shown here :

J7			J6			
GND	B1	o o A1	IOCHK	GND	C0	o o D0
RESET	B2	o o A2	BD7	SBHE	C1	o o D1
+5V	B3	o o A3	BD6	LA23	C2	o o D2
IRQ9	B4	o o A4	BD5	LA22	C3	o o D3
-5V	B5	o o A5	BD4	LA21	C4	o o D4
DRQ2	B6	o o A6	BD3	LA20	C5	o o D5
-12V	B7	o o A7	BD2	LA19	C6	o o D6
OWS	B8	o o A8	BD1	LA18	C7	o o D7
+12V	B9	o o A9	BD0	LA17	C8	o o D8
GND	B10	o o A10	IOCHRDY	MEMR	C9	o o D9
MEMW	B11	o o A11	AEN	MEMW	C10	o o D10
MEMR	B12	o o A12	SA19	SD8	C11	o o D11
IOW	B13	o o A13	SA18	SD9	C12	o o D12
IOR	B14	o o A14	SA17	SD10	C13	o o D13
DACK3	B15	o o A15	SA16	SD11	C14	o o D14
DRQ3	B16	o o A16	SA15	SD12	C15	o o D15
DACK1	B17	o o A17	SA14	SD13	C16	o o D16
DRQ1	B18	o o A18	SA13	SD14	C17	o o D17
REFRESH	B19	o o A19	SA12	SD15	C18	o o D18
SYSCLK	B20	o o A20	SA11	KEY	C19	o o D19
IRQ7	B21	o o A21	SA10			
IRQ6	B22	o o A22	SA9			
IRQ5	B23	o o A23	SA8			
IRQ4	B24	o o A24	SA7			
IRQ3	B25	o o A25	SA6			
DACK2	B26	o o A26	SA5			
TC	B27	o o A27	SA4			
BALE	B28	o o A28	SA3			
+5V	B29	o o A29	SA2			
OSC	B30	o o A30	SA1			
GND	B31	o o A31	SA0			
GND	B32	o o A32	GND			

2.13 Connector Jumper Summary

Connector/ Jumper	Description	Page Reference
J1	Configuration Options Jumper	2-3
J2	Bus Size Selection Jumper	2-2
J3	Jumpered vs. Jumperless select jumper	2-3
J4	BNC Thin Ethernet Connector	N/A
J5	Not Used	N/A
J6	PC/104-16 Bus Connector	2-14
J7	PC/104-8 Bus Connector	2-14

APPENDIX A

DP83905 AT/LANTIC™ Controller Datasheet

dp83905_atlantic.pdf

APPENDIX B

PCM-NE2000-BNC Schematic Diagram

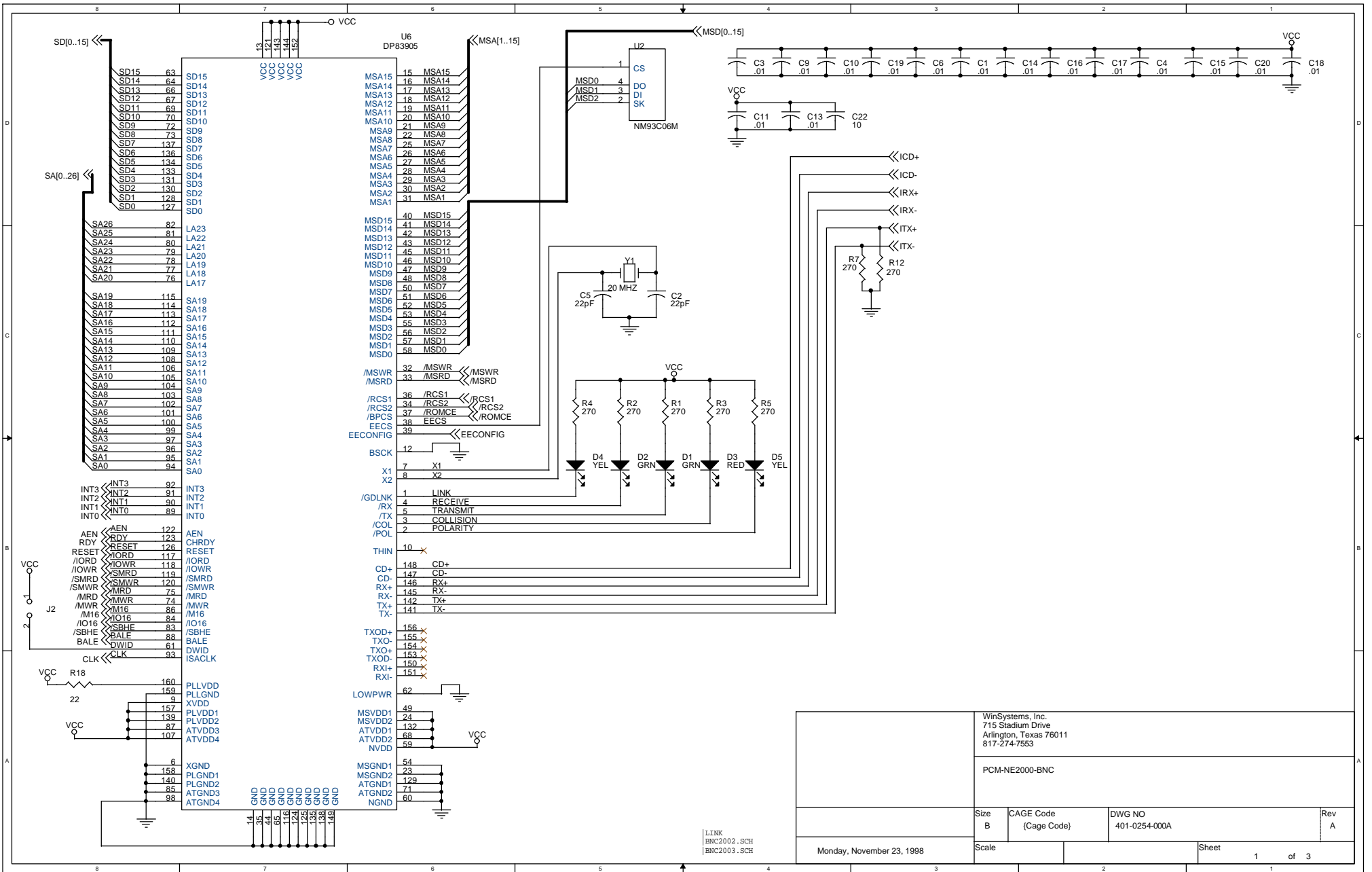

LINK
BNC2002.SCH
BNC2003.SCH

WinSystems, Inc. 715 Stadium Drive Arlington, Texas 76011 817-274-7553			
PCM-NE2000-BNC			
Size B	CAGE Code (Cage Code)	DWG NO 401-0254-000A	Rev A
Monday, November 23, 1998		Scale	Sheet 1 of 3

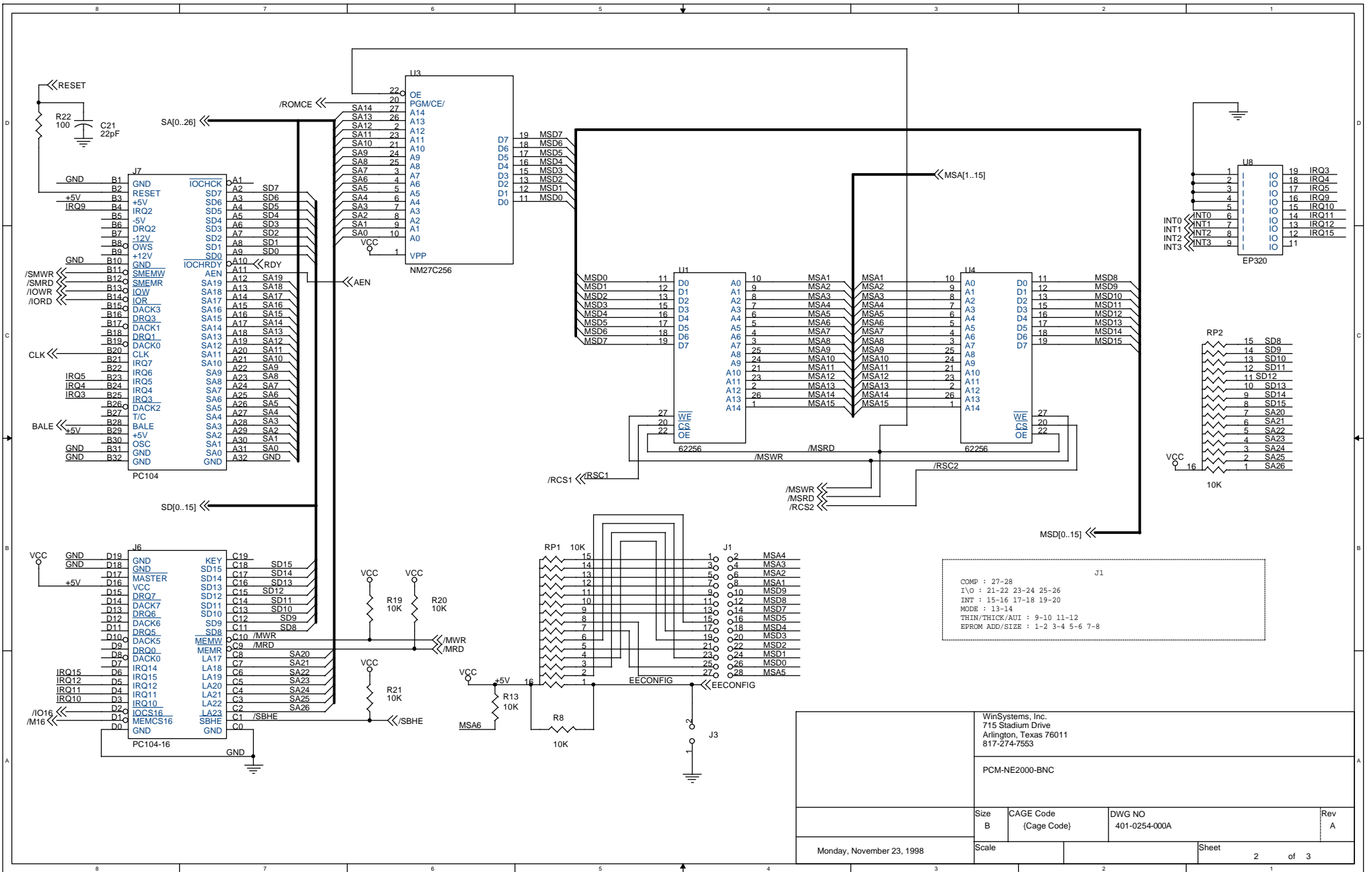

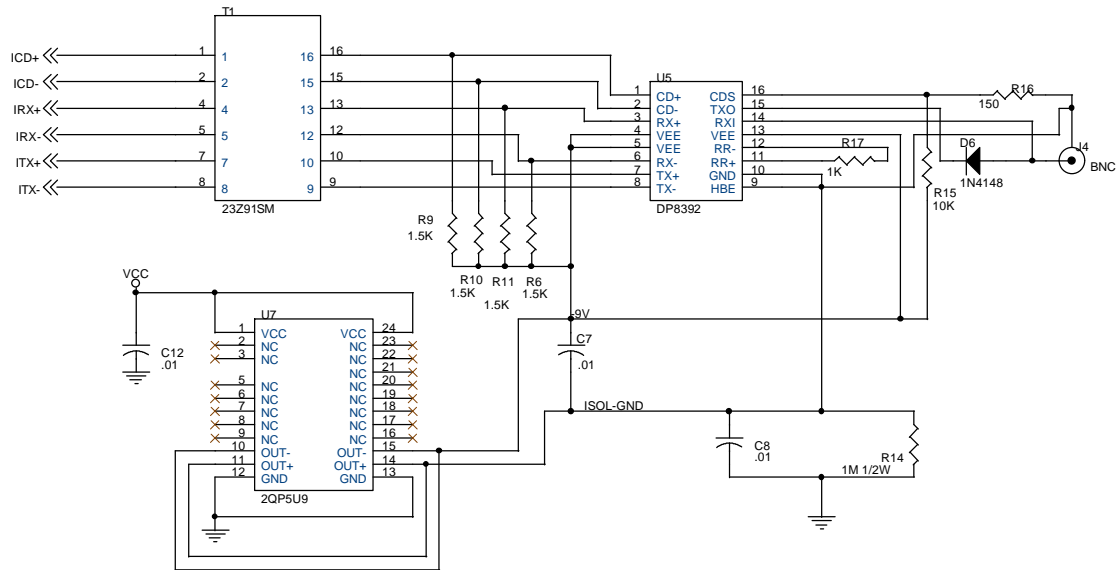

WinSystems, Inc. 715 Stadium Drive Arlington, Texas 76011 817-274-7553			
PCM-NE2000-BNC			
Size B	CAGE Code (Cage Code)	DWG NO 401-0254-000A	Rev A
Monday, November 23, 1998	Scale	Sheet	3 of 3

WARRANTY

WinSystems warrants that for a period of two (2) years from the date of shipment any Products and Software purchased or licensed hereunder which have been developed or manufactured by WinSystems shall be free of any material defects and shall perform substantially in accordance with WinSystems' specifications therefore. With respect to any Products or Software purchased or licensed hereunder which have been developed or manufactured by others, WinSystems shall transfer and assign to Customer any warranty of such manufacturer or developer held by WinSystems, provided that the warranty, if any, may be assigned. The sole obligation of WinSystems for any breach of warranty contained herein shall be, at its option, either (i) to repair or replace at its expense any materially defective Products or Software, or (ii) to take back such Products and Software and refund the Customer the purchase price and any license fees paid for the same. Customer shall pay all freight, duty, broker's fees, insurance changes and other fees and charges for the return of any Products or Software to WinSystems under this warranty. WinSystems shall pay freight and insurance charges for any repaired or replaced Products or Software thereafter delivered to Customer within the United States. All fees and costs for shipment outside of the United States shall be paid by Customer. The foregoing warranty shall not apply to any Products or Software which have been subject to abuse, misuse, vandalism, accidents, alteration, neglect, unauthorized repair or improper installations.

THERE ARE NO WARRANTIES BY WINSYSTEMS EXCEPT AS STATED HEREIN. THERE ARE NO OTHER WARRANTIES EXPRESS OR IMPLIED INCLUDING, BUT NOT LIMITED TO, THE IMPLIED WARRANTIES OF MERCHANTABILITY AND FITNESS FOR A PARTICULAR PURPOSE, IN NO EVENT SHALL WINSYSTEMS BE LIABLE FOR CONSEQUENTIAL, INCIDENTAL, OR SPECIAL DAMAGES INCLUDING, BUT NOT LIMITED TO, DAMAGES FOR LOSS OF DATA, PROFITS OR GOODWILL. WINSYSTEMS' MAXIMUM LIABILITY FOR ANY BREACH OF THIS AGREEMENT OR OTHER CLAIM RELATED TO ANY PRODUCTS, SOFTWARE, OR THE SUBJECT MATTER HEREOF, SHALL NOT EXCEED THE PURCHASE PRICE OR LICENSE FEE PAID BY CUSTOMER TO WINSYSTEMS FOR THE PRODUCTS OR SOFTWARE OR PORTION THEREOF TO WHICH SUCH BREACH OR CLAIM PERTAINS.

WARRANTY SERVICE

All products returned to WinSystems must be assigned a Return Material Authorization (RMA) number. To obtain this number, please call or FAX WinSystems' factory in Arlington, Texas and provide the following information:

1. Description and quantity of the product(s) to be returned including its serial number.
2. Reason for the return.
3. Invoice number and date of purchase (if available), and original purchase order number.
4. Name, address, telephone and FAX number of the person making the request.
5. Do not debit WinSystems for the repair. WinSystems does not authorize debits.

After the RMA number is issued, please return the products promptly. Make sure the RMA number is visible on the outside of the shipping package.

The customer must send the product freight prepaid and insured. The product must be enclosed in an anti-static bag to protect it from damage caused by static electricity. Each bag must be completely sealed. Packing material must separate each unit returned and placed as a cushion between the unit(s) and the sides and top of the shipping container. WinSystems is not responsible for any damage to the product due to inadequate packaging or static electricity.