

OPERATIONS MANUAL

PCM-SC520

NOTE: *This manual has been designed and created for use as part of the WinSystems' Technical Manuals CD and/or the WinSystems' web site. If this manual or any portion of the manual is downloaded, copied or emailed, the links to additional information (i.e. software, cable drawings) will be inoperable.*

WinSystems reserves the right to make changes in the circuitry and specifications at any time without notice.
©Copyright 2008 by WinSystems. All Rights Reserved.

REVISION HISTORY

P/N 400-0326-000

ECO Number	Date Code	Rev Level
	050516	Preliminary
	060721	A.1
07-46	070328	A.2
07-135	070803	A.3
08-40	080328	A.4
09-62	090625	A.5

Table of Contents

Visual Index – Quick Reference	i
Top View - Connectors	i
Top View - Jumpers	ii
Bottom View	iii
Introduction	1
General Information	1
Features	1
Functional Capability	2
Processor	2
Memory	2
BIOS	2
Rotational Disk Support	3
Solid State Disk (SSD) Support	3
CompactFlash	5
Direct Memory Access (DMA)	5
Interrupts	5
Ethernet Controller	5
Status LED	6
Serial Communications	6
Line Printer Port	9
Keyboard	9
Mouse Controller	9
Timers	9
Real-Time Clock/Calendar	9
Watchdog Timer	10
Reset	10
Battery Back-up	11
Master Battery Enable (J11)	11
Speaker	11
PC/104 Bus Interface	12
Power	13

BIOS Supplemental	14
I/O Port Map	32
Interrupt Map	33
Cables	34
Software Drivers & Examples	35
Mechanical Drawing	36
Jumper Reference	37
Specifications	41
WARRANTY REPAIR INFORMATION	42

Visual Index – Quick Reference

Top View - Connectors

For the convenience of the user, a copy of the Visual Index has been provided with direct links to connector and jumper configuration data.

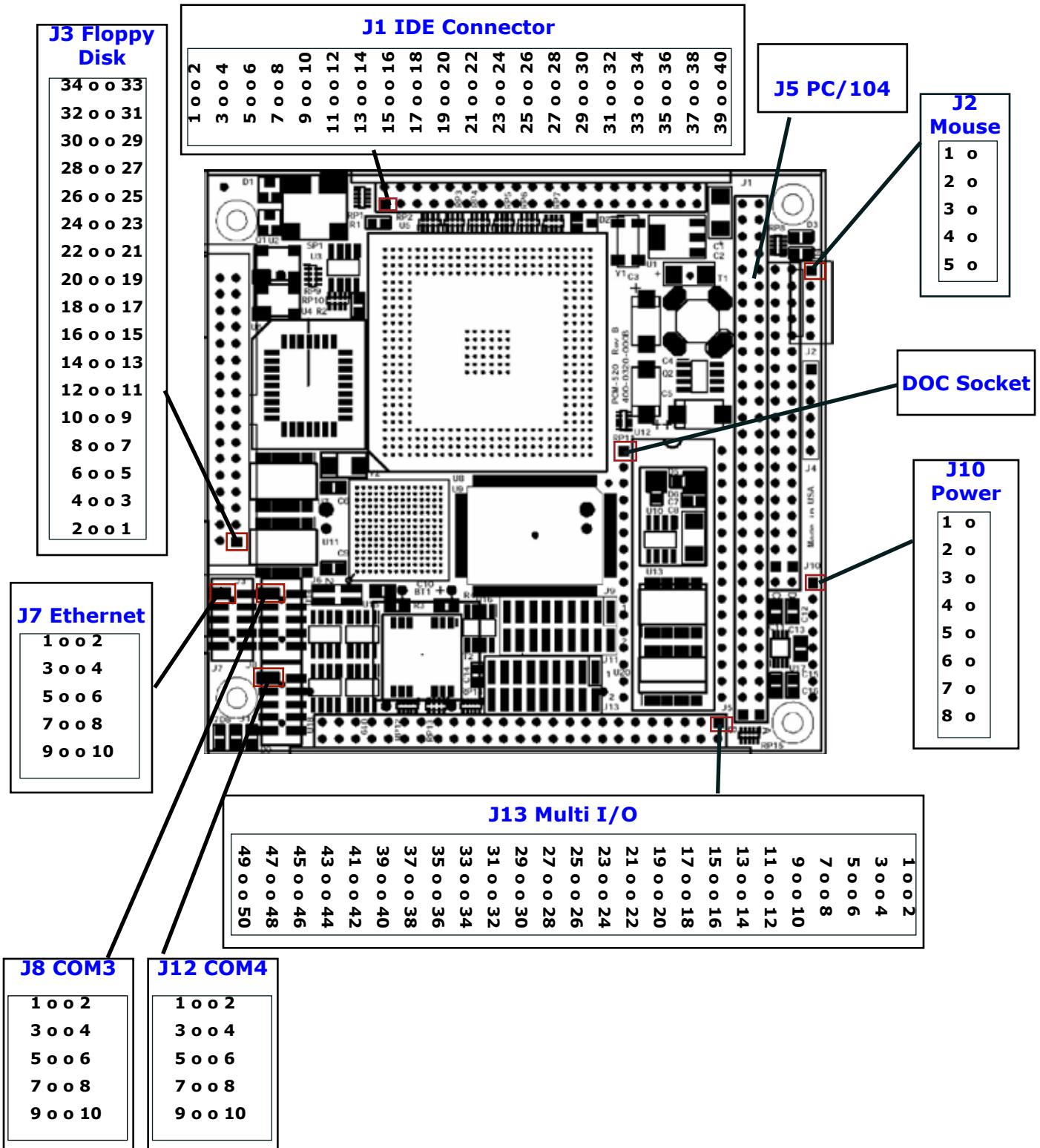

NOTE: The reference line to each component part has been drawn to Pin 1, where applicable. Pin 1 is also highlighted with a red square, where applicable.

Visual Index – Quick Reference

Top View - Jumpers

For the convenience of the user, a copy of the Visual Index has been provided with direct links to connector and jumper configuration data.

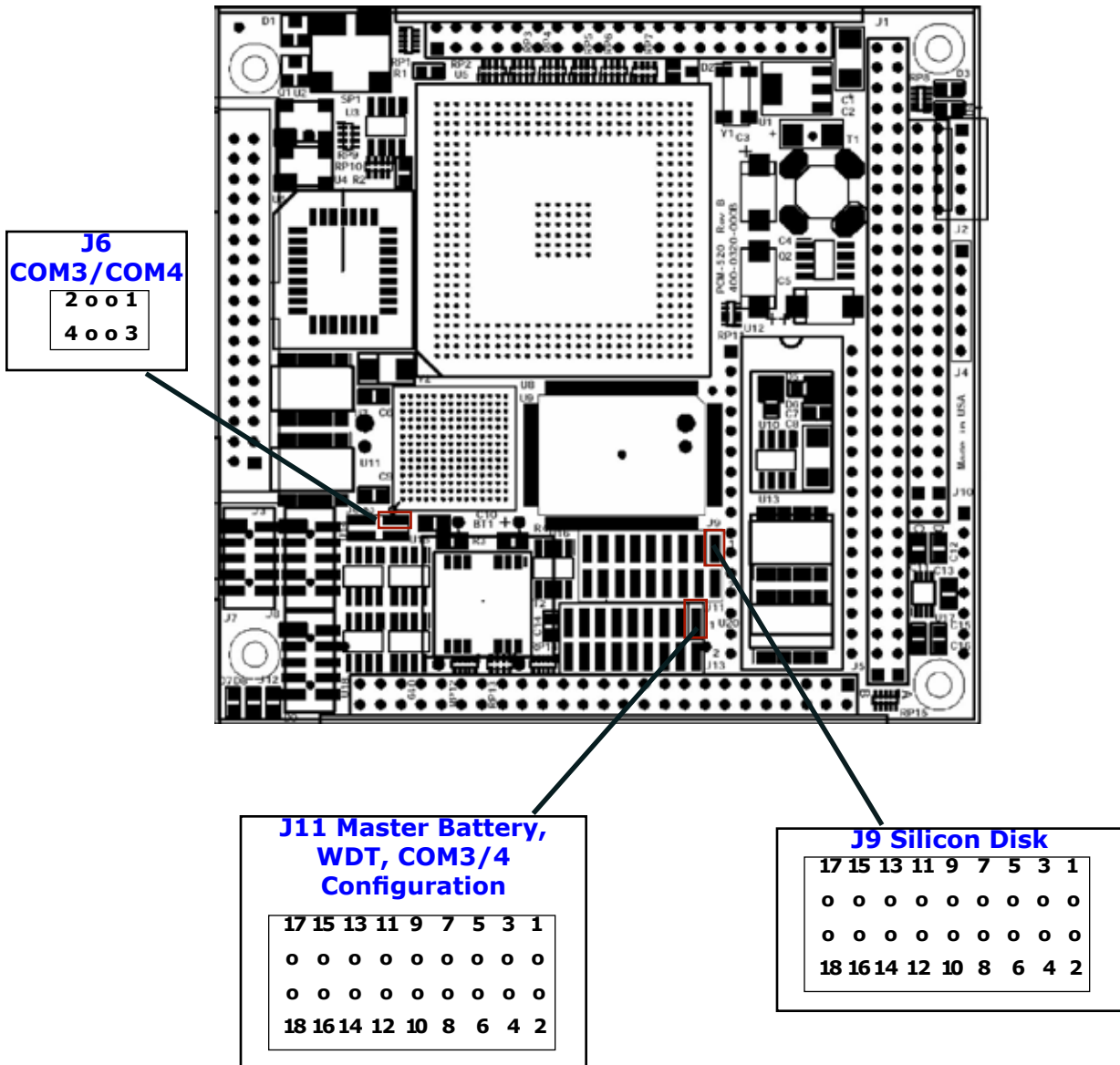

NOTE: The reference line to each component part has been drawn to Pin 1, where applicable. Pin 1 is also highlighted with a red square, where applicable.

Visual Index – Quick Reference

Bottom View

For the convenience of the user, a copy of the Visual Index has been provided with direct links to connector and jumper configuration data.

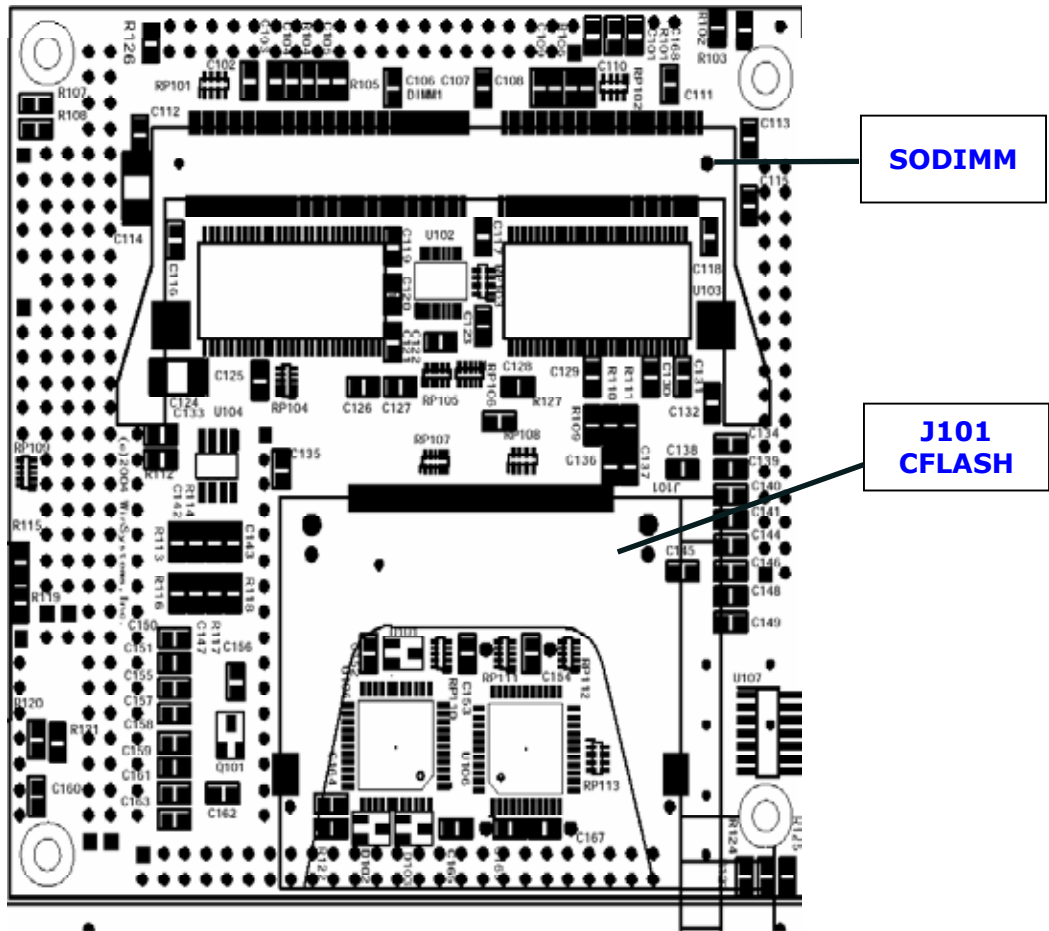

NOTE: The reference line to each component part has been drawn to Pin 1, where applicable. Pin 1 is also highlighted with a red square, where applicable.

Introduction

This manual is intended to provide the necessary information regarding configuration and usage of the PCM-SC520 board. WinSystems maintains a Technical Support Group to help answer questions regarding usage, or programming of the board. For answers to questions not adequately addressed in this manual, contact Technical Support at (817) 274-7553 between 8 a.m. and 5 p.m. Central Standard Time.

General Information

Features

- 133 MHz AMD SC520 CPU
- Supports Windows®, Linux and other x86-compatible operating systems
- PC/104-compliant form factor
- Up to 256 MB of SDRAM using SODIMM
- Socket for bootable DiskOnChip®, SDRAM, or EPROM
- Type I and II Compact Flash (CF) cards supported
- Industry standard Phoenix BIOS
- Intel 82551ER 10/100 Ethernet controller
- Four (4) RS-232 serial ports with FIFO, COM3 & COM4 also with RS-422/485 support
- Bi-directional LPT port supports EPP/ECP
- On-board EIDE hard disk interface
- Floppy disk controller supports 1 or 2 drives
- x86-compatible interrupt and DMA controllers
- Three (3) 16-bit counter/timers
- AT keyboard controller and PS/2 mouse port
- 16-bit PC/104 expansion connector
- Watchdog timer and power fail reset
- Up to 200 second reset on watchdog timer
- Real-time clock with battery backup
- Status, hard disk and Ethernet activity LEDs
- Speaker header for remote PC speaker
- Small size: 3.6 in x 3.8 in (90 mm x 96 mm)
- Replaces WinSystems' PCM-SX and PCM-586
- Only +5 volts required
- Low power, no fan required
- -40°C to +85°C temperature range
- RoHS compliant

The PCM-SC520 is an x86-compatible, PC/104-compatible, single board computer with on-board Ethernet support for network-enabled applications. Because of its small size and low power consumption, it is well suited for portable and mobile products. The PCM-SC520 is the upgrade and replacement for WinSystems' PCM-SX and PCM-586 boards.

It is powered by an AMD SC520 CPU operating at 133 MHz. A 10/100 Ethernet controller provides high-speed Ethernet access in addition to four serial COM ports. Up to 256MB of memory can be installed in a SODIMM socket. Also, DiskOnChip® disks and CompactFlash cards can be installed for on-board solid state flash storage.

Functional Capability

Processor

This board is based upon an AMD 133 MHz SC520. The SC520 incorporates the CPU, FPU, DRAM Controller, Flash/ROM Controller, PCI Controller, RTC/CMOS RAM, and Chip selects for DOC support and the IDE interface.

The AMD processor is based upon 0.25 – micron process technology that allows for low power consumption. It is supplied in a 388-pin PBGA package, that is soldered directly to the board at the factory. This part is not user replaceable or upgradeable. The core CPU runs at a base clock frequency of 33 MHz. An internal software controlled multiplier of either 3X or 4X results in internal processor speeds of either 100 MHz or 133 MHz.

The PCM-SC520 supports the revision 2.2 version of the 32-bit PCI bus at a speed of 33 MHz. This is used for an internal connection with the Ethernet controller.

Memory



The PCM-SC520 can support a maximum of 256 MB of RAM. Two versions of the board are available: either 0 MB of RAM or, the board can be built with 32 MB of SDRAM soldered directly to the PCB. **(This factory installed option is for applications that are subject to severe shock and vibration.** Contact a WinSystems Application Engineer for details.) Additional RAM memory, up to 256 MB, can be installed at the SODIMM socket by the user. RAM memory must meet the following criteria:

32, 64, 128, 256 MB 144-Pin SODIMM SDRAM PC66, minimum, with gold fingers

WinSystems-qualified SODIMMs are available directly from WinSystems. WinSystems cannot warrant the operation of systems using non-qualified SODIMM modules.

Installation is accomplished by inserting the module into the connector on the back of the board at approximately a 30° (degree) angle. Press firmly to fully seat the module into the connector and then press the module downward to snap it into the retaining clamps.

Removal is accomplished by gently pulling outward on the retaining clamps until the module springs up to the appropriate removal angle.

BIOS

An industry-standard, Phoenix BIOS provides configuration flexibility, performance and AT-compatibility. It is loaded with a factory default that can be changed by the user. The BIOS is located in an EEPROM that can be modified without removing the storage device from the board. The PCM-SC520 will operate without a keyboard or video.

Rotational Disk Support

Up to two, 3.5" or 5.25" floppy disk drives are supported. Also an industry-standard 16-bit IDE interface is provided to support up to two hard disks. A status LED **D3** provides visual status during IDE data transfers.



J3 Floppy Disk Interface

DRVEN0	2 0 0 1	GND
N/C	4 0 0 3	GND
DRVEN1	6 0 0 5	GND
INDEX	8 0 0 7	GND
MTR0	10 0 0 9	GND
DS1	12 0 0 11	GND
DS0	14 0 0 13	GND
MTR1	16 0 0 15	GND
DIR	18 0 0 17	GND
STEP	20 0 0 19	GND
WDATA	22 0 0 21	GND
WGATE	24 0 0 23	GND
TRK0	26 0 0 25	GND
WRTPRT	28 0 0 27	GND
RDATA	30 0 0 29	GND
HDSEL	32 0 0 31	GND
DSKCHG	34 0 0 33	GND

J1 IDE Connector

RESET	1 0 0 2	GND
D7	3 0 0 4	D8
D6	5 0 0 6	D9
D5	7 0 0 8	D10
D4	9 0 0 10	D11
D3	11 0 0 12	D12
D2	13 0 0 14	D13
D1	15 0 0 16	D14
D0	17 0 0 18	D15
GND	19 0 0 20	N/C
GND	21 0 0 22	GND
IOW	23 0 0 24	GND
IOR	25 0 0 26	GND
N/C	27 0 0 28	ALE
N/C	29 0 0 30	GND
INTRQ	31 0 0 32	IOCS16
A1	33 0 0 34	N/C
A0	35 0 0 36	A2
HDSC0	37 0 0 38	HDSC1
N/C	39 0 0 40	GND

Solid State Disk (SSD) Support

The PCM-SC520 supports several types of solid state storage devices for applications where the environment is too harsh for mechanical hard disks or floppy drives. The PCM-SC520 can support CompactFlash, SRAM, EPROM and DiskOnChip® devices.

A JEDEC standard 32-pin, machine-tooled socket, **U12**, is provided to accept an M-Systems' DiskOnChip® (DOC). The DOC offers from 16 MB to 1 GB of storage capacity in a single device. It includes an internal flash file system that provides hard disk read/write compatibility, automatic bad block management, and wear-leveling. WinSystems stocks industrial temperature range DOCs.

The socket is mapped into an adjustable hole in the system memory space. Jumper field **J9** allows the user to select the device type, the hole size and location, paged mode vs. non-paged mode and enable battery backup to the socket. When using paged-mode operation, the page register is located at 1ECH.

The PCM-SC520 ships with this socket configured for DOC operation located at address E000:00.



DiskOnChip® (DOC)

	17-18	15-16	13-14	11-12	9-10	7-8	5-6	3-4	1-2
C800:0	OFF	ON		ON	ON	ON	ON	ON	ON
CC00:0	OFF	ON		ON	ON	OFF	ON	ON	ON
D000:0	OFF	ON		ON	OFF	ON	ON	ON	ON
D400:0	OFF	ON		ON	OFF	OFF	ON	ON	ON
D800:0	OFF	ON		OFF	ON	ON	ON	ON	ON
DC00:0	OFF	ON		OFF	ON	OFF	ON	ON	ON
E000:0	OFF	ON		OFF	OFF	ON	ON	ON	ON
E400:0	OFF	ON		OFF	OFF	OFF	ON	ON	ON

EPROM

16K window	17-18	15-16	13-14	11-12	9-10	7-8	5-6	3-4	1-2
C800:0	OFF	ON		ON	ON	ON	OFF	ON	ON
CC00:0	OFF	ON		ON	ON	OFF	OFF	ON	ON
D000:0	OFF	ON		ON	OFF	ON	OFF	ON	ON
D400:0	OFF	ON		ON	OFF	OFF	OFF	ON	ON
D800:0	OFF	ON		OFF	ON	ON	OFF	ON	ON
DC00:0	OFF	ON		OFF	ON	OFF	OFF	ON	ON
E000:0	OFF	ON		OFF	OFF	ON	OFF	ON	ON
E400:0	OFF	ON		OFF	OFF	OFF	OFF	ON	ON

32K window	17-18	15-16	13-14	11-12	9-10	7-8	5-6	3-4	1-2
C800:0	ON	OFF		ON	ON	OFF	OFF	ON	OFF
D000:0	ON	OFF		ON	OFF	OFF	OFF	ON	OFF
D800:0	ON	OFF		OFF	ON	OFF	OFF	ON	OFF
E000:0	ON	OFF		OFF	OFF	OFF	OFF	ON	OFF

64K window	17-18	15-16	13-14	11-12	9-10	7-8	5-6	3-4	1-2
D000:0	ON	OFF		X	X	OFF	OFF	OFF	ON

SRAM

32K window	17-18	15-16	13-14	11-12	9-10	7-8	5-6	3-4	1-2
C800:0	ON	OFF		ON	ON	OFF	OFF	ON	OFF
D000:0	ON	OFF		ON	OFF	OFF	OFF	ON	OFF
D800:0	ON	OFF		OFF	ON	OFF	OFF	ON	OFF
E000:0	ON	OFF		OFF	OFF	OFF	OFF	ON	OFF

64K window	17-18	15-16	13-14	11-12	9-10	7-8	5-6	3-4	1-2
D000:0	ON	OFF		X	X	OFF	OFF	OFF	ON

CompactFlash

The CompactFlash socket at **J101** will support modules with true IDE support. WinSystems offers CompactFlash modules that have been qualified with our boards for -40°C to +85°C extended temperature environments. A **RED** IDE activity LED is present at **D3**.

When using a CompactFlash device, Master/Slave mode selection is made using pins 13-14 of jumper field **J9**.

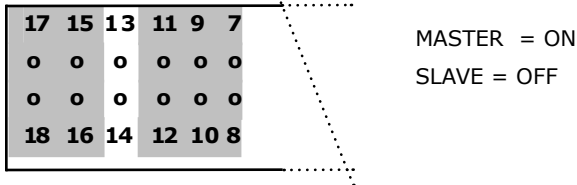

Direct Memory Access (DMA)

DMA is supported. Channel 2 is dedicated to the floppy disk controller. The LPT is plug-and-play configurable. The other DMA channels are wired to the PC/104 connector.

Interrupts

Two 82C59A-compatible interrupt controllers accept inputs from the on-board peripherals and the PC/104 Bus connectors.

Ethernet Controller

An Intel 82551ER (the connector is located at **J7**) is the 32-bit PCI Ethernet controller chip used for high-speed data transfer. It has auto negotiation capability for speed, duplex, and flow control. It supports IEEE 802.3 10-BaseT and 100BaseT in either full- or half-duplex mode at both 10 and 100 Mbps. In full-duplex mode, it adheres to the IEEE 802.x Flow Control Specification.

Two large 3 KB transmit and receive FIFOs help prevent data underruns and overruns. It has fast back-to-back transmission support with minimum interframe spacing. It also has improved dynamic transmit chaining with multiple priorities transmit queues. There are three light-emitting diodes (LEDs) on the PPM-10/100 to provide a visual indication of the link status, network activity and network speed. The yellow Link Integrity LED is lit when there is a valid connection detected. The green Activity LED blinks on and off when activity is detected on the wire. The red LED is on if a 100BASE-T link is detected and off if a 10BASE-T link is detected.

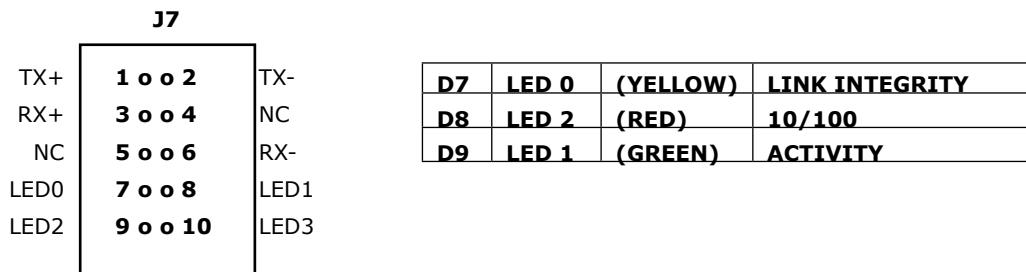

Visual Index

Visual Index

The 82551ER chip is very popular both in the commercial and industrial PC-compatible market. This means that most PC-compatible drivers, utilities and 10/100 Ethernet supported operating systems will work directly with the PCM-SC520. The configuration information describing the device's architecture, address, interrupt, etc. is stored in a serial EEPROM.

NOTE: WinSystems cannot provide technical support for direct programming of the 82551ER controller. We suggest utilizing a TCP/IP stack or Network O/S that allows the use of preexisting 82551ER drivers.

The 82551 is software compatible with the Intel line of Pro 100+ PCI adapters. The 82551 is supported by a number of operating systems directly. Intel provides the latest drivers through their web site at:

<http://www.intel.com/design/network/drivers>

Status LED

An on-board LED can be used by software for signaling status or error conditions. The LED is illuminated by writing a 1 to I/O port 1EDH. The LED is turned off by writing a 0 to I/O address 1EDH.

D3	(RED)	IDE ACTIVITY
D4	(RED)	User programmable status LED

Serial Communications

Four independent, full-duplex, RS-232 asynchronous serial channels are on-board. All serial channels are configured as Data Terminal Equipment (DTE). Both the send and receive registers of each channel have a 16-byte FIFO. All serial ports have dual 16C550-compatible UARTs that offer software compatibility with PC-type driver programs.



Independent control of transmit, receive, line status and data set interrupts are on all channels. Each channel is setup to provide internal diagnostics such as loopback and echo mode on the data stream. An independent on-chip software programmable baud rate generator is selectable from 50 through 115.2 Kbps. Individual modem handshake control signals are supported for all channels.

RS-232 interface levels are supported on all four channels. The RS-232 drivers have an on-chip charge pump to generate the plus and minus voltages so that the PCM-SC520 only requires +5 volts to operate.

COM1 and COM2 are wired to a 50-pin connector, **J13**, at the edge of the board. WinSystems offers the optional [CBL-247-1](#), which adapts each serial channel to 9-pin male "D" connectors.

J13 – COM1/COM2 Connector

COM1

RS-232	J13	RS-232
DCD	1 2	DSR
RXD	3 4	RTS
TXD	5 6	CTS
DTR	7 8	RI
GND	9	

COM2

RS-232	J13	RS-232
	10	DCD
DSR	11 12	RXD
RTS	13 14	TXD
CTS	15 16	DTR
RI	17 18	GND

J13 Pin Definitions

COM1*	1 0 0 2	COM1*
COM1*	3 0 0 4	COM1*
COM1*	5 0 0 6	COM1*
COM1*	7 0 0 8	COM1*
COM1*	9 0 0 10	COM2*
COM2*	11 0 0 12	COM2*
COM2*	13 0 0 14	COM2*
COM2*	15 0 0 16	COM2*
COM2*	17 0 0 18	COM2*
LPT-STROBE	19 0 0 20	LPT-AUTOFD
LPT-PD0	21 0 0 22	LPT-ERROR
LPT-PD1	23 0 0 24	LPT-INIT
LPT-PD2	25 0 0 26	LPT-SLCTIN
LPT-PD3	27 0 0 28	LPT-GND
LPT-PD4	29 0 0 30	LPT-GND
LPT-PD5	31 0 0 32	LPT-GND
LPT-PD6	33 0 0 34	LPT-GND
LPT-PD7	35 0 0 36	LPT-GND
LPT-ACK	37 0 0 38	LPT-GND
LPT-BUSY	39 0 0 40	LPT-GND
LPT-PE	41 0 0 42	LPT-GND
LPT-SLCT	43 0 0 44	KEYBD-GND
KEYBD-GND	45 0 0 46	KEYBD-GND
KEYBD-KDATA	47 0 0 48	KEYBD-CLK
KEYBD-+5V	49 0 0 50	KEYBD-+5V

* **NOTE:** Pins 1-9 are used for COM1, pins 10-18 are used for COM2.

In addition to the RS-232 interface, COM3 and COM4 also have jumper-selectable RS-422/485 support. The RS-422/485 provides separate balanced transmit and receive signal pairs. For RS-485 multi-drop lines, one signal pair can be used for "party line" network structures. COM3 and COM4 are each wired to a 10-pin, 2 mm connector on the board at **J8** and **J12** respectively. WinSystems offers the optional [CBL-123-5](#), which adapts each of the COM3 and COM4 serial channels to 9-pin male "D" connectors.

Line Printer Port

The LPT port is a multi-mode parallel printer port that supports the PS/2 standard bi-directional parallel port (SPP), Enhanced Parallel Port (EPP), or Extended Capabilities Port (ECP). The output drivers support 14 mA per line.



The LPT is wired to a 50-pin connector, **J13**, at the edge of the board. WinSystems offers the optional cable [CBL-247-1](#) which adapts the LPT port to a 25-pin male "D" connector.

The printer port can also be used as two additional general-purpose I/O ports if a printer is not required. The first port is configured as 8 input or output only lines. The other port is configured as 5 input and 3 output lines.

Keyboard

An integrated 80C42 equivalent keyboard controller supports a PC/AT-type keyboard. The keyboard is wired to a 50-pin connector, **J13**, at the edge of the board. WinSystems offers the cable [CBL-247-1](#), which adapts the keyboard interface to a PS/2 style keyboard connector.



Mouse Controller

A PS/2 mouse port, **J2**, and interface cable, part number [CBL-225-1](#) provides a PS/2 connection for a compatible mouse.



J2 Pin Assignments

1	MSDATA
2	N/C
3	GND
4	VCC
5	MSCLK

Timers

Three, independent 82C54 compatible 16-bit timers are supported.

Real-Time Clock/Calendar

A real-time clock is used as the AT-compatible clock/calendar. It supports a number of features including periodic and alarm interrupt capabilities. In addition to the time and date keeping functions, the system configuration is kept in CMOS RAM contained within the clock section.

Watchdog Timer

The PCM-SC520 board features a power-on voltage detect and power brown-out reset circuit to protect memory and I/O from faulty operation during periods of out-of-tolerance voltage levels. This supervisor circuitry also features a watchdog timer, **J11**, which can be used to guard against software lockups. An internal self-timer will, when enabled, reset the CPU if the watchdog has not been serviced within the allotted time.

When a jumper is placed on pins 5-6 of **J11**, the watchdog circuit is totally disabled and can never reset the processor.

With the jumper removed from 5-6, and a jumper on pins 3-4, a software-enabled 1.5 second reset interval is selected. Enabling is accomplished by writing a **1** to I/O port 1EEH. Writing a **0** to I/O port 1EEH will disable the watchdog. After enabling, petting may be accomplished by writing any value to I/O port 1EFH within the timeout period. The CPU will reset if the watchdog has not been serviced within the allotted time.

A jumper on pins 7-8 selects a 200 second reset interval that is hard-wired enabled at power-up. The interval can be switched to 1.5 seconds by writing a **1** to I/O port 1EEH. Writing a **0** to I/O port 1EEH will switch the time interval back to 200 seconds. The watchdog must be serviced within the allotted time by writing any value to I/O port 1EFH.

Note: It is recommended that the long timeout (200 seconds) be used with the watchdog enabled when trying to boot any operating system.

Watchdog Timer (J11)

	3-4	5-6	7-8
DISABLE	OFF	ON	OFF
1.5 SECOND	ON	OFF	OFF
200 SECOND	OFF	OFF	ON

Software ENABLE = PORT 1EEH, BIT 0.

Software watchdog timer PET = PORT 1EFH, write any value.

Reset

A precision voltage comparator monitors the +5 volt status. Upon detection of an out-of-tolerance condition, the board is reset. This action is critically important in order to detect brown-out or power fail conditions. The reset circuit also ensures that the power is nominal before executing a power-on reset. This circuit also inhibits the processor's memory write line, preventing invalid data from being written to non-volatile memory during power fluctuations.

Battery Back-up

A 350 mAH battery supplies the PCM-SC520 board with standby power for the real-time clock and CMOS set-up RAM.

A power supervisory circuit contains the voltage-sensing circuit and an internal power switch to route the battery or stand-by voltage to the circuits selected for backup. The battery automatically switches ON when the VCC of the systems drops below the battery voltage and back OFF again when VCC returns to normal.

Master Battery Enable (J11)

	1-2
ENABLE	ON
DISABLE	OFF

Speaker

An on-board speaker is available for sound generation. A beep code is generated that corresponds to any BIOS error codes (if required) during the power up or reset sequence.

PC/104 Bus Interface

The PCM-SC520 provides a PC/104 expansion bus connector at **J5**. PC/104 modules are self-stacking and plug together in a “piggy back” configuration to serve as a mezzanine expansion bus. The pin definitions for the 8-bit and 16-bit portions are shown here.



J5 PC/104 BUS CONNECTOR

GND1	B1 ○ ○ A1	IOCHK	GND1	D0 ○ ○ C0	GND
RESET	B2 ○ ○ A2	SD7	MEMCS16	D1 ○ ○ C1	SBHE
+5V	B3 ○ ○ A2	SD6	IOCS16	D2 ○ ○ C2	LA23
IRQ2	B4 ○ ○ A4	SD5	IRQ10	D3 ○ ○ C3	LA22
-5V	B5 ○ ○ A5	SD4	IRQ11	D4 ○ ○ C4	LA21
DRQ2	B6 ○ ○ A6	SD3	IRQ12	D5 ○ ○ C5	LA20
-12V	B7 ○ ○ A7	SD2	IRQ15	D6 ○ ○ C6	LA19
OWS	B8 ○ ○ A8	SD1	IRQ14	D7 ○ ○ C7	LA18
+12V	B9 ○ ○ A9	SD0	DACK0	D8 ○ ○ C8	LA17
GND2	B10 ○ ○ A10	IOCHRDY	DRQ0	D9 ○ ○ C9	MEMR
SMEMW	B11 ○ ○ A11	AEN	DACK5	D10 ○ ○ C10	MEMW
SMEMR	B12 ○ ○ A12	SA19	DRQ5	D11 ○ ○ C11	SD8
IOW	B13 ○ ○ A13	SA18	DACK6	D12 ○ ○ C12	SD9
IOR	B14 ○ ○ A14	SA17	DRQ6	D13 ○ ○ C13	SD10
DACK3	B15 ○ ○ A15	SA16	DACK7	D14 ○ ○ C14	SD11
DRQ3	B16 ○ ○ A16	SA15	DRQ7	D15 ○ ○ C15	SD12
DACK1	B17 ○ ○ A17	SA14	VCC	D16 ○ ○ C16	SD13
DRQ1	B18 ○ ○ A18	SA13	MASTER	D17 ○ ○ C17	SD14
DACK0	B19 ○ ○ A19	SA12	GND2	D18 ○ ○ C18	SD15
CLK	B20 ○ ○ A20	SA11	GND3	D19 ○ ○ C19	KEY
IRQ7	B21 ○ ○ A21	SA10			
IRQ6	B22 ○ ○ A22	SA9			
IRQ5	B23 ○ ○ A23	SA8			
IRQ4	B24 ○ ○ A24	SA7			
IRQ3	B25 ○ ○ A25	SA6			
DACK2	B26 ○ ○ A26	SA5			
T/C	B27 ○ ○ A27	SA4			
BALE	B28 ○ ○ A28	SA3			
+5V1	B29 ○ ○ A29	SA2			
OSC	B30 ○ ○ A30	SA1			
GND3	B31 ○ ○ A31	SA0			
GND4	B32 ○ ○ A32	GND			

Power

Power is brought into the board through an 8-pin connector, **J10**. Both +/-12 volts are wired directly to the PC/104 connector and not used by the PCM-SC520.



J10

1	-12V
2	+12V
3	+5V
4	+5V
5	GND
6	GND
7	GND
8	PBRESET

BIOS Supplemental

General Information

The PCM-SC520 comes equipped with a standard Phoenix BIOS to assure full compatibility with PC operating systems and software. The basic system configuration is stored in battery-backed CMOS RAM within the clock/calendar. The configuration may alternatively be stored in an EEPROM for batteryless operation. Access to this setup information is via the Setup utility in the Phoenix BIOS.

Entering Setup

To enter Setup, power up the computer and press **F2** when either the splash screen is displayed (when enabled) or when the "**Press F2 for Setup**" message is displayed. Alternately, under certain error conditions a message similar to : "**Press F1 to Continue or F2 for Setup**" may be displayed. Press the desired key for the appropriate action. The BIOS will display the message: "**Entering Setup**" and will continue with the remainder of the POST routines. It may take a number of seconds before the main setup menu screen is displayed.

Setup Main Menu

Each of the available options will be discussed in this section. Use the '**Up**' and '**Down**' arrow keys to move among the sections. Use the '**Left**' and '**Right**' arrow keys to move to another menu page. Hit '**+**' or '**-**' to scroll through selections or hit '**Enter**' when a selection is highlighted to enter a sub-menu or to see a list of choices.

Main Menu Screen

PhoenixBIOS Setup Utility			
Main	Advanced	Boot	Exit
System Time:		11:34:27	Item Specific Help ----- <Tab>, <Shift-Tab>, or <Enter> selects field.
System Date:		08/08/2007	
Legacy Diskette A:		[1.44/1.2 MB 1/2"]	
Legacy Diskette B:		[Disabled]	
Primary Master		[None]	
Primary Slave		[None]	
System Memory:		640 KB	
Extended Memory:		63 MB	

F1 Help	↑↓ Select Item	+/- Change Values	F9 Setup Defaults
Esc Exit	Select Menu	Enter Select → Sub-Menu	F10 Save and Exit

System Time: This option allows for the setting of the time in the clock/calendar. **"Enter"** is used to move from hours, to minutes, to seconds while the **" +/- "** keys adjust the value.

System Date: This option allows for the setting the calendar to the current month, day, and year. Movement from field to field is accomplished with the **"Enter"** key. Values are changed using **" +/- "** keys adjust the value.

Legacy Diskette A: This option allows for setting the type of the first floppy drive attached. If no drive is attached, **"Disabled"** should be selected.

The available options are:

- Disabled
- 360 KB 5 1/4"
- 1.2 MB 5 1/4"
- 720 KB 3 1/2"
- 1.44/1.25 MB 3 1/2"
- 2.88 MB 3 1/2"

Legacy Diskette B: This option allows for setting the type of the second floppy drive attached. If no drive is attached, "**Disabled**" should be selected.

The available options are:

- Disabled
- 360 KB 5¹/₄"
- 1.2 MB 5¹/₄"
- 720 KB 3¹/₂"
- 1.44/1.25 MB 3¹/₂"
- 2.88 MB 3¹/₂"

Legacy Diskette A: This option allows for setting the type of the first floppy drive attached. If no drive is attached, "**Disabled**" should be selected.

The available options are:

- Disabled
- 360 KB 5¹/₄"
- 1.2 MB 5¹/₄"
- 720 KB 3¹/₂"
- 1.44/1.25 MB 3¹/₂"
- 2.88 MB 3¹/₂"

Primary Master: This option sets the drive type for the first fixed disk. Unlike older systems with fixed drive type numbers, the Phoenix BIOS relies primarily on the self-identification feature of modern IDE drives. This allows the BIOS to auto-detect the drive type and parameters. Support is also provided for user-defined drive parameter definitions as well as support for Bootable CD-ROMs and removable ATAPI drives.

The available options are:

- Auto
- None
- CD-ROM
- ATAPI Removable
- User

When no fixed disk is to be attached, select "**None**" to minimize startup time. The "**Auto**" mode is the most versatile and works with nearly all modern hard disks, CD-ROMs, and ATAPI-Removable drives.

Primary Slave: This option sets the drive type for the second fixed disk. Unlike older systems with fixed drive type numbers, the Phoenix BIOS relies primarily on the self-identification feature of modern IDE drives. This allows the BIOS to auto-detect the drive type and parameters.

The available options are:

- Auto
- None
- CD-ROM
- ATAPI Removable
- User

When no fixed disk is to be attached, select "**None**" to minimize startup time. The "**Auto**" mode is the most versatile and works with nearly all modern hard disks, CD-ROMs, and ATAPI-Removable drives.

System Memory: This field is displayed by the BIOS and cannot be changed. It shows the amount of memory below 1 MB that the system found.

Extended Memory: This is also a display only field. It represents the amount of extended memory above 1 MB that was found in the system.

Advanced CMOS Setup

The Advanced CMOS setup allows for the configuration of all of the non-disk related Setup items. There are several sub-menus that allow control of a number of System and Chipset Features. Each of the setup options will be discussed in the sections that follow.

Advanced CMOS Setup Screen

The screenshot shows the PhoenixBIOS Setup Utility interface. At the top, it says "PhoenixBIOS Setup Utility". Below that, there are four menu options: "Main", "Advanced" (which is highlighted), "Boot", and "Exit". The main area is divided into two columns. The left column contains a "Setup Warning" message, a list of menu items ("Advanced Chipset Control", "PCI Configuration", "I/O Device Configuration", "Keyboard Features"), and three configuration items: "Installed O/S: [Win95]", "Reset Configuration Data: [No]", and "Large Disk Access [DOS]". The right column is titled "Item Specific Help" and contains instructions: "<Tab>, <Shift-Tab>, or <Enter> selects field." At the bottom, there is a blue bar with keyboard shortcuts: "F1 Help", "Esc Exit", "Up/Down arrows Select Item/Select Menu", "+/- Change Values", "Enter Select Sub-Menu", "F9 Setup Defaults", and "F10 Save and Exit".

PhoenixBIOS Setup Utility					
Main	Advanced	Boot	Exit		
Setup Warning Setting items on this menu to incorrect values may cause your system to malfunction.			Item Specific Help		
Advanced Chipset Control PCI Configuration I/O Device Configuration Keyboard Features			<Tab>, <Shift-Tab>, or <Enter> selects field.		
Installed O/S: [Win95]					
Reset Configuration Data: [No]					
Large Disk Access [DOS]					
F1 Help	↑ ↓ Select Item	+/- Change Values	F9 Setup Defaults		
Esc Exit	Select Menu	Enter Select Sub-Menu	F10 Save and Exit		

Advanced Chipset Control: This sub-menu allows configuration of the chipset portion of the AMD SC520 processor/chipset. Each of the selections will be discussed in the following sections.

CPU Speed: This option allows for setting the CPU operating speed. In all cases, the base frequency is 33 MHz and it's internal CPU divisor is changed by this option. The available options are:
 133 MHz (default)
 100 MHz

Cache Mode: The SC520 has an on-chip 16 KB cache. The cache mode may be configured using this setup menu option. The available options are:
 Write Back (default)
 Write Through

Advanced Chipset Control

-- Advanced Chipset Control Sub-menu Screen --

PhoenixBIOS Setup Utility	
Main	Advanced Boot Exit
Advanced Chipset Control	
	Item Specific Help
CPU Speed:	[133]
Cache Mode:	[Write Back]
CAS Latency:	[2T]
RAS to CAS Delay:	[2T]
RAS Precharge Time:	[2T]
Refresh Cycle Time:	[15.6 us]
SDRAM Buffer:	[Enabled]
Delay Transaction	[Enabled]
Host-PCI Write Buffer	[Enabled]

F1 Help	↑↓ Select Item	+/- Change Values	F9 Setup Defaults
Esc Exit	Select Menu	Enter Select → Sub-Menu	F10 Save and Exit

- CAS Latency: This selection allows the cache latency time to be varied by a number of (T) clock cycles. The available options are:
3T (default)
2T
- RAS to CAS Delay: This selection allows for the control of the RAS to CAS timing delay. It is also expressed in clock (T) cycles. The available options are:
2T (default)
3T
4T
- RAS Pre-charge Time: This selection controls the pre-charge time for DRAM cycles. It is expressed in clock (T) cycles. The available options are:
2T (default)
3T
4T
6T
- Refresh Cycle Time: This selection allows control of the SDRAM refresh timing. This selection must match the requirements of the SDRAM actually installed. The available options are:
7.8 us
15.6 us (default)
31.2 us
62.5 us
- SDRAM Buffer: This selection allows for enabling or disabling the SDRAM buffer function. The available options are:
Enabled (default)
Disabled
- Delay Transaction: This selection allows for configuring the delayed transaction processing feature. The available options are:
Enabled (default)
Disabled
- Host-PCI Write Buffer: This selection allows for control of the Host-PCI write buffer. The available options are:
Enabled (default)
Disabled

PCI Configuration

This menu allows configuration of the PCI bus resources. This menu should only be used by knowledgeable users. It is possible to configure the PCI resources so as not to allow the on-board peripherals to function due to lack of resources.

The sections that follow will describe each of the menu items and selections.

-- PCI Configuration Sub-menu Screen --

PhoenixBIOS Setup Utility																	
Main	Advanced																
Boot	Exit																
PCI Configuration	Item Specific Help																
PCI Device, Slot #1 PCI Device, Slot #2 PCI Device, Slot #3 PCI IRQ Line 1: [Auto Select] PCI IRQ Line 2: [Auto Select] PCI IRQ Line 3: [Auto Select] PCI IRQ Line 4: [Auto Select] PCI/PNP ISA UMB Region Exclusion PCI/PNP ISA IRW Exclusion ISA Graphics device installed [No]	Setup items for Configuring the Specific PCI Device																
<table border="1"> <tr> <td>F1</td> <td>Help</td> <td>↑↓</td> <td>Select Item</td> <td>+/-</td> <td>Change Values</td> <td>F9</td> <td>Setup Defaults</td> </tr> <tr> <td>Esc</td> <td>Exit</td> <td></td> <td>Select Menu</td> <td>Enter</td> <td>Select → Sub-Menu</td> <td>F10</td> <td>Save and Exit</td> </tr> </table>		F1	Help	↑↓	Select Item	+/-	Change Values	F9	Setup Defaults	Esc	Exit		Select Menu	Enter	Select → Sub-Menu	F10	Save and Exit
F1	Help	↑↓	Select Item	+/-	Change Values	F9	Setup Defaults										
Esc	Exit		Select Menu	Enter	Select → Sub-Menu	F10	Save and Exit										

PCI Device Slot #1: This sub-menu allows control of several parameters relating to modules attached as the PCI Slot 1 device. These include:

- Option ROM Scan: If the PCI Device contains a BIOS extension, its scan can be controlled using this option.
- Enable Master: This selection allows the device to serve as a PCI bus master if enabled.
- Latency Timer: This selection controls the latency timer value. The available options are:
 - Default
 - 0020h
 - 0040h
 - 0060h
 - 0080h
 - 00A0h
 - 00C0H
 - 00E0H

PCI Device Slot #2: This sub-menu allows control of several parameters relating to modules attached as the PCI Slot 2 device. These include:

- Option ROM Scan: If the PCI Device contains a BIOS extension, its scan can be controlled using this option.
- Enable Master: This option allows the device to serve as a PCI bus master if enabled.
- Latency Timer: This selection controls the latency timer value. The available options are:
 - Default
 - 0020h
 - 0040h
 - 0060h
 - 0080h
 - 00A0h
 - 00C0H
 - 00E0H

PCI Device Slot #3: This sub-menu allows control of several parameters relating to modules attached as the PCI Slot 3 device. These include:

- Option ROM Scan: If the PCI Device contains a BIOS extension, its scan can be controlled using this option.
- Enable Master: This option allows the device to serve as a PCI bus Master if enabled.
- Latency Timer: This selection controls the latency timer value. The available options are:
 - Default
 - 0020h
 - 0040h
 - 0060h
 - 0080h
 - 00A0h
 - 00C0H
 - 00E0H

PCI IRQ Line 1: This option selects the IRQ to be routed to IRQ Line 1 (A). The available options are:

- Disabled
- Auto Select
- 3
- 4
- 5
- 7
- 9
- 10
- 11
- 12
- 14
- 15

PCI IRQ Line 2: This option selects the IRQ to be routed to IRQ Line 2 (B). The available options are:

- Disabled
- Auto Select
- 3
- 4
- 5
- 7
- 9
- 10
- 11
- 12
- 14
- 15

PCI IRQ Line 3: This option selects the IRQ to be routed to IRQ Line 3 (C).
The available options are:
Disabled
Auto Select
3
4
5
7
9
10
11
12
14
15

PCI IRQ Line 4: This option selects the IRQ to be routed to IRQ Line 4 (D).
The available options are:
Disabled
Auto Select
3
4
5
7
9
10
11
12
14
15

PCI/PNP ISA UMB Region Exclusion: This menu option allows specific upper memory blocks to be reserved so that they will not be used by PCI or ISA PnP devices. There are six (6) address blocks that may be individually selected as either **"Available"** or **"Reserved"**.

These blocks are:

- C800 - CBFF
- CC00 - CFFF
- D000 - D3FF
- D400 - D7FF
- D800 - DBFF
- DC00 - DFFF

PCI/PNP ISA IRQ Resource Exclusion: This option like the previous one, allows a resource (IRQ) to be reserved so that it will not be assigned to a PCI or ISA PnP device. Each of the listed IRQs may either be selected as **"Available"** or **"Reserved"**.

The selectable IRQ resources are:

- IRQ 3
- IRQ 4
- IRQ 5
- IRQ 7
- IRQ 9
- IRQ 11
- IRQ 15

ISA Graphics Device Installed:

This option when selected **"Yes"** allows a ISA (Non-VGA) graphics device to access palette data in the PCI VGA device. The available options are:
Yes
No

I/O Device Configuration

This menu allows configuration of peripheral devices. Each of the menu options will be discussed in the sections that follow.

The sections that follow will describe each of the menu items and selections.

-- I/O Configuration Sub-menu Screen --

PhoenixBIOS Setup Utility		
Main	Advanced	Boot Exit
I/O Configuration		Item Specific Help
SC520 IDE Adapter:	[Enabled]	Enable the integrated SC520 IDE adapter.
Floppy disk controller:	[Enabled]	
SC520 Serial Port A:	[Enabled]	
SC520 Serial Port B:	[Enabled]	
Serial Port A:	[Auto]	
Serial Port B:	[Auto]	
Parallel Port:	[Auto]	
Mode:	[Bi-directional]	

F1 Help	↑↓ Select Item	+/- Change Values	F9 Setup Defaults
Esc Exit	Select Menu	Enter Select → Sub-Menu	F10 Save and Exit

SC520 IDE Adapter: This configuration option controls the internal IDE interface. The available options are:
Enabled
Disabled

When no IDE devices are to be connected, turning this option to "**Disabled**" will result in a significant reduction in the time to boot.

Floppy Disk Controller: This option controls the configuration of the floppy disk controller. The available options are:
Enabled
Disabled

SC520 Serial Port A: This option configures the first serial port (COM1). The available options are:
Enabled
Disabled

SC520 Serial Port B: This option configures the second serial port (COM2). The available options are:
Enabled
Disabled

Serial Port A: This option controls the first serial port in the SMSC 37C727 super I/O chip (COM3). The available options are:
Enabled
Disabled
Auto
OS Controlled

When the Port is selected as "**Enabled**", two sub-menu choices become visible:

Base I/O Address: This selection configures the base I/O address. The available options are:
3E8H
2E8H
3A8H
2A8H

Interrupt: This selects the desired interrupt for this port. The available options are:
IRQ 9
IRQ 11

Serial Port B:

This option controls the second serial port in the SMSC 37C727 super I/O chip (COM4). The available options are:

- Enabled
- Disabled
- Auto
- OS Controlled

When the Port is selected as "**Enabled**", two sub-menu choices become visible:

Base I/O Address: This selection configures the base I/O address. The available options are:

- 3E8H
- 2E8H
- 3A8H
- 2A8H

Interrupt: This selects the desired interrupt for this port. The available options are:

- IRQ 9
- IRQ 11

Parallel Port:

This option controls the configuration of the on-board printer port. The available options are:

- Enabled
- Disabled
- Auto
- OS Controlled

Mode: This sub-menu allows selection of the parallel port operating mode. The available options are:

- Output only
- Bi-directional
- EPP
- ECP

When the Port is selected as "**Enabled**", two sub-menu choices become visible:

Base I/O Address: This option selects the base I/O address. The available options are:

- 378
- 278
- 3BC

Interrupt: This option selects the parallel port interrupt. The available options are:

- IRQ 5
- IRQ 7

Keyboard Features

This menu allows for configuration of the keyboard operating parameters. These are four items on this menu. Each of the selections will be discussed in the section that follows.

Num Lock: This option determines the status of the Num Lock LED. The available options are:
Auto
On
Off

Key Click: This selection enables or disables the sound produced when a key is pressed. The available options are:
Disabled
Enabled

Keyboard Auto Repeat Rate: This option controls the repeat rate (typematic) when a key is held down. The available options are:
30/sec
26.7/sec
21.8/sec
18.5/sec
13.3/sec
10/sec
6/sec
2/sec

Keyboard Auto Repeat Delay: This option controls the time that a key must be held down before it begins to repeat. The available options are:
1/4 sec
1/2 sec
3/4 sec
1 sec

Miscellaneous Features

The following items are also present on the Advanced Setup Menu.

Installed OS: This feature allows for the selection of O/S type. The available options are:
Win 95
Other (This option must be selected for Windows CE to properly address the Ethernet port.)

Reset Configuration Data: This option when enabled, resets the PnP and other configuration data which may be programmed by the BIOS into its Flash memory. This will cause all devices and settings to be fully enumerated at the next boot. The available options are:
No
Yes

Large Disk Access: This option sets the Large disk (greater than 528 MB) access mode. The available options are:
Other
DOS

Boot Setup

This menu screen allows selection of a number of Boot options. Each of the menu items will be described in the following sections.

Boot Setup Screen

PhoenixBIOS Setup Utility											
Main	Advanced	Boot	Exit								
Summary screen:		[Enabled]	Item Specific Help								
QuickBoot Mode:		[Enabled]									
Boot-time Diagnostic Screen		[Disabled]	Display system configuration on boot								
		+Removable Devices									
		+Hard Drive									
		Atapi CD-ROM Drive									
		Network Boot									
<table border="0"> <tr> <td>F1 Help</td> <td>↑↓ Select Item</td> <td>+/- Change Values</td> <td>F9 Setup Defaults</td> </tr> <tr> <td>Esc Exit</td> <td>Select Menu</td> <td>Enter Select → Sub-Menu</td> <td>F10 Save and Exit</td> </tr> </table>				F1 Help	↑↓ Select Item	+/- Change Values	F9 Setup Defaults	Esc Exit	Select Menu	Enter Select → Sub-Menu	F10 Save and Exit
F1 Help	↑↓ Select Item	+/- Change Values	F9 Setup Defaults								
Esc Exit	Select Menu	Enter Select → Sub-Menu	F10 Save and Exit								

Summary Screen: This option allows for control of the system summary screen. When enabled, a configuration box will be displayed for three seconds prior to boot. The available options are:

- Enabled
- Disabled

QuickBoot Mode: This option allows for a shortened POST process. When this option is **"Enabled"**, the memory test is shortened significantly, reducing the time to boot. The available options are:

- Disabled
- Enabled

Boot-time Diagnostic Screen: This option allows control of the Splash screen and the BIOS Post and sign-on messages. When **"Enabled"**, the splash screen is off, and the BIOS messages will be displayed. Refer to the section on the [Logo utility](#) for information on creating custom BIOS Splash screens. The available options are:

- Disabled
- Enabled

Boot Order: This option allows the available boot devices to be ordered according to the desired boot priority. Removable devices (floppy), hard disks, CD-ROM drives, and network boot items may be moved up or down the priority list using the keys as shown on the boot menu screen.

Exit Setup

This menu screen is used for exiting the setup menu and for saving or discarding any changes made.

Exit Saving Changes: This option, when selected, saves all of the changes made to the CMOS RAM and exits the Setup Utility. A warm start re-boot is attempted. In some cases, depending upon system conditions and changes made, the re-start will not be successful and either a power-down or a manual reset may be required.

Exit Saving Changes to EEPROM: This option saves the current status of all selections the on-board EEPROM. The function allows changes to be saved for operation without a battery. **WARNING:** First verify all settings by saving the CMOS RAM and testing. If bad configurations are written to EEPROM, it may be possible that the CPU will not boot and be unrecoverable.

Exit Discarding Changes: This option exits the Setup Utility and re-starts the system. Any changes made (other than Date/Time will not be saved).

Load Setup Defaults: This option, when selected, loads the CMOS RAM with all factory defaults.

Discard Changes: This option removes any changes made but does not exit the setup utility.

Save Changes: This option saves all changes made to the CMOS RAM but does not exit the setup utility.

Phlash Utility

The Phoenix BIOS on board the PCM-SC520 is stored in Flash memory. BIOS updates may be programmed on board using the Phoenix Phlash Utility. *Phlash.exe* is a DOS executable that may be run from the command prompt such as: **plash bios.rom**

This will execute the *PHLASH.EXE* program and start re-programming of the BIOS with the specified file, *BIOS.ROM*. The Phlash utility also requires the presence of the file *PLATFORM.BIN*. The utility can be run from floppy, hard disk, or DiskOnChip®. It may also be run "in the blind" without keyboard or video present by adding its invocation into the AUTOEXEC.BAT file on the boot media.

Logo Utility

The *LOGO.EXE* Utility combined with the *BMP2PGX.EXE* program and MS-Windows *PAINT.EXE* allows for the creation of a custom splash screen that will be displayed during the BIOS post process. The steps for creating a custom splash screen are:

1. In Windows Paint or another graphic utility capable of generating Windows .BMP files, create your desired screen with a resolution of 640 X 480 pixels in 16 colors. This resolution and color count must be adhered to if the graphic is to be displayed properly. Save the file in a .BMP format.

2. Run the *BMP2PGX.EXE* utility to convert the .BMP file to a .PGX file which is a compressed graphic format used by the Phoenix BIOS display manager. The invocation line is as follows:

bmp2pgx logo.bmp

This will create the .PGX file required for the next step. The name will be the same as the .BMP file with a .PGX extension.

3. Run the *LOGO.EXE* utility to place the new .PGX file into the BIOS image file. If the BIOS image file is named *BIOS.ROM* and the logo file is called *LOGO.PGX*, then the command: **logo bios.rom logo.pgx** will load the new logo file into the *BIOS.ROM* file at the proper position.

4. Use the *Phlash.exe* utility described in the previous section to program the new BIOS image.

5. Using the BIOS Setup, on the Boot Menu, Disable the Boot-time Diagnostic Screen. During the POST routines, your screen will be displayed. You can still press <ESCAPE> to return to the diagnostic screen or <F2> to enter setup.

I/O Port Map

The following is a list of PC I/O ports. Addresses marked with a “-” are not used on the PCM-SC520, but their use should be carefully evaluated so as not to conflict with other I/O boards. I/O addresses marked with a “+” are used on the PCM-SC520 and are unique to the WinSystems design. I/O addresses marked with “***” are generally unused and should be the basis for the first choices in I/O address selection for external I/O boards.

NOTE: The PCM-SC520 uses a PnP BIOS resource allocation. Care must be taken to avoid contention with resources allocated by the BIOS.

<u>Hex Range</u>	<u>Usage</u>
000-00F	8237DMA Controller #1
**010-01F	Free
020-021	8259 PIC #1
**022-03F	Free
040-043	8254 PIT
**044-05F	Free
060-06F	8042 Keyboard / Mouse Controller
070-07F	CMOS RAM, Clock / Calendar
080-09F	DMA Page Registers
0A0-0BF	8259 PIC #2
0C0-0DF	8237 DMA Controller #2
**0E0-0EF	Free
0F0-0F1	Math Co-processor Control
**0F2-0F7	Free
0F8-0FF	Math Co-processor
100-102	Video Controllers
**103-1EC	Free
1ED-1EF	Watchdog/LED control
1F0-1FF	IDE Controller #1
**200-277	Free
**278-27F	Free – (** option for LPT)
**280-2A7	Free
**2A8-2AF	Free – (* option for Serial Port)
2B0-2DF	Video Controllers
**2E0-2E7	Free
2E8-2EF	COM4 – (* Default)
**2F0-2F7	Free
2F8-2FF	COM2
**300-377	Free
378-37F	LPT (** Default)
**380- 3A7	Free
**3A8- 3AF	Free – (* option for Serial Port)
3B0-3DF	Video Controllers
**3E0-3E7	Free
3E8- 3EF	COM3 – (* Default)
3F0-3F7	Floppy Disk Controller #1
3F8-3FF	COM1

Interrupt Map

Hardware Interrupts (IRQs) are supported for both PC/104 (ISA) and PC/104*Plus* (PCI) devices. The user must reserve IRQs in the BIOS CMOS configuration for use by legacy devices. The PCI/PnP BIOS will use unreserved IRQs when allocating resources during the boot process. The table below lists IRQ resources as used by the PCM-SC520.

IRQ0 18.2 Hz heartbeat
IRQ1 Keyboard
IRQ2 Chained to Slave controller
IRQ3 COM2
IRQ4 COM1
IRQ5 Not Used (* option for LPT)
IRQ6 Floppy Disk
IRQ7 LPT (*)
IRQ8 Real Time Clock
IRQ9 COM3 (* option for COM4)
IRQ10 Used only for PC/104Plus
IRQ11 COM4 (* option for COM3)
IRQ12 Mouse
IRQ13 Unavailable
IRQ14 IDE Hard Disk
IRQ15 Not Used

* These IRQ reference are default settings that can be changed by the user in the CMOS Settings utility. Reference the PCI Configurations section under Advanced Settings.

Cables

Part Number	Description
CBL-SET-320-1	Various cables for the PCM-SC520 includes:
CBL-123-5	COM 3 & 4 serial DTE cable
CBL-174-1	Power cable for SBC (unterminated) NOTE: Wiring does not follow conventional ATX color codes. +/-12V = color.
CBL-225-1	PS/2 mouse adapter
CBL-247-1	Multi-I/O cable with PS/2 keyboard connector
CBL-267-2	6-foot cable with Ethernet jack
CBL-267-3	1-foot cable with Ethernet plug

Software Drivers & Examples

Latest BIOS and Update utility	pcm520_rel0216.zip
Drivers for Intel 82551ER/82559ER 10/100 Ethernet Controller	
Linux Kernels - 2.4.x & 2.6.x kernels	e100-3.5.14.tar.gz
Latest known to compile for 2.2.x kernels	e100-2.1.15.tar.gz
NDIS4 (Windows 98)	82559erWin98.zip
NDIS4 (Windows NT 4 & 2000)	e100ndis4.zip
Windows NT Embedded 4.0	e100ent.zip
Windows XP/2000	e100exp.zip
Windows CE 3.0	e100ce3.zip
Windows CE.NET	e100ce.zip
DOS	e100bdos.zip
DOS Packet Drivers	packet.zip
Example of reprogramming DOS tick for high resolution timing	tickdemo.zip
Serial Console Utilities:	
Generic 38400baud Serial console redirect for COM1	scon1.zip
Generic 38400baud Serial console redirect for COM2	scon2.zip
Generic 9600baud Serial console redirect for COM1	sc19600.zip
Generic 9600baud Serial console redirect for COM2	sc29600.zip

Mechanical Drawing

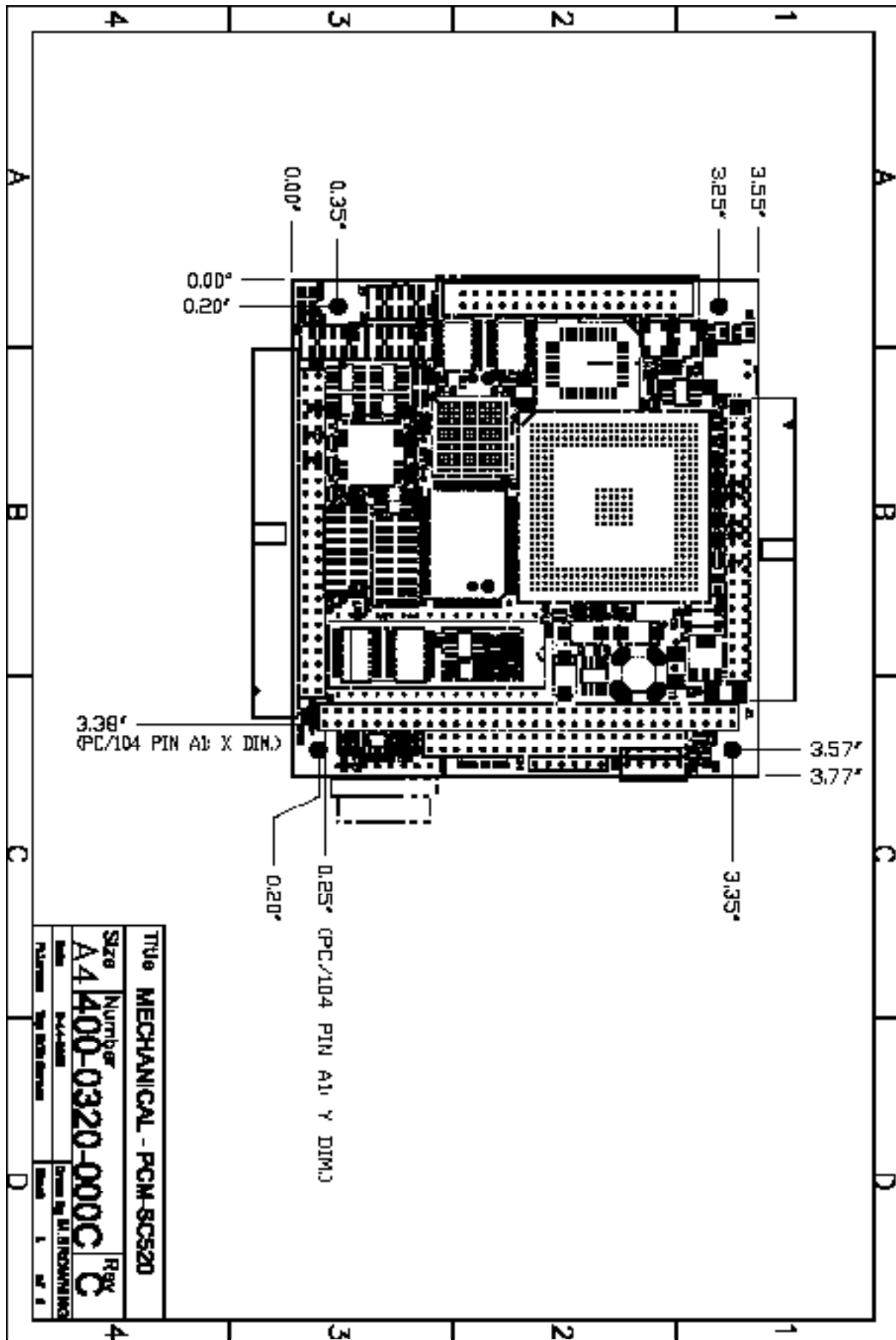

Jumper Reference

Drawings ONLY - for more detailed information on these parts, refer to the descriptions shown previously in this manual.

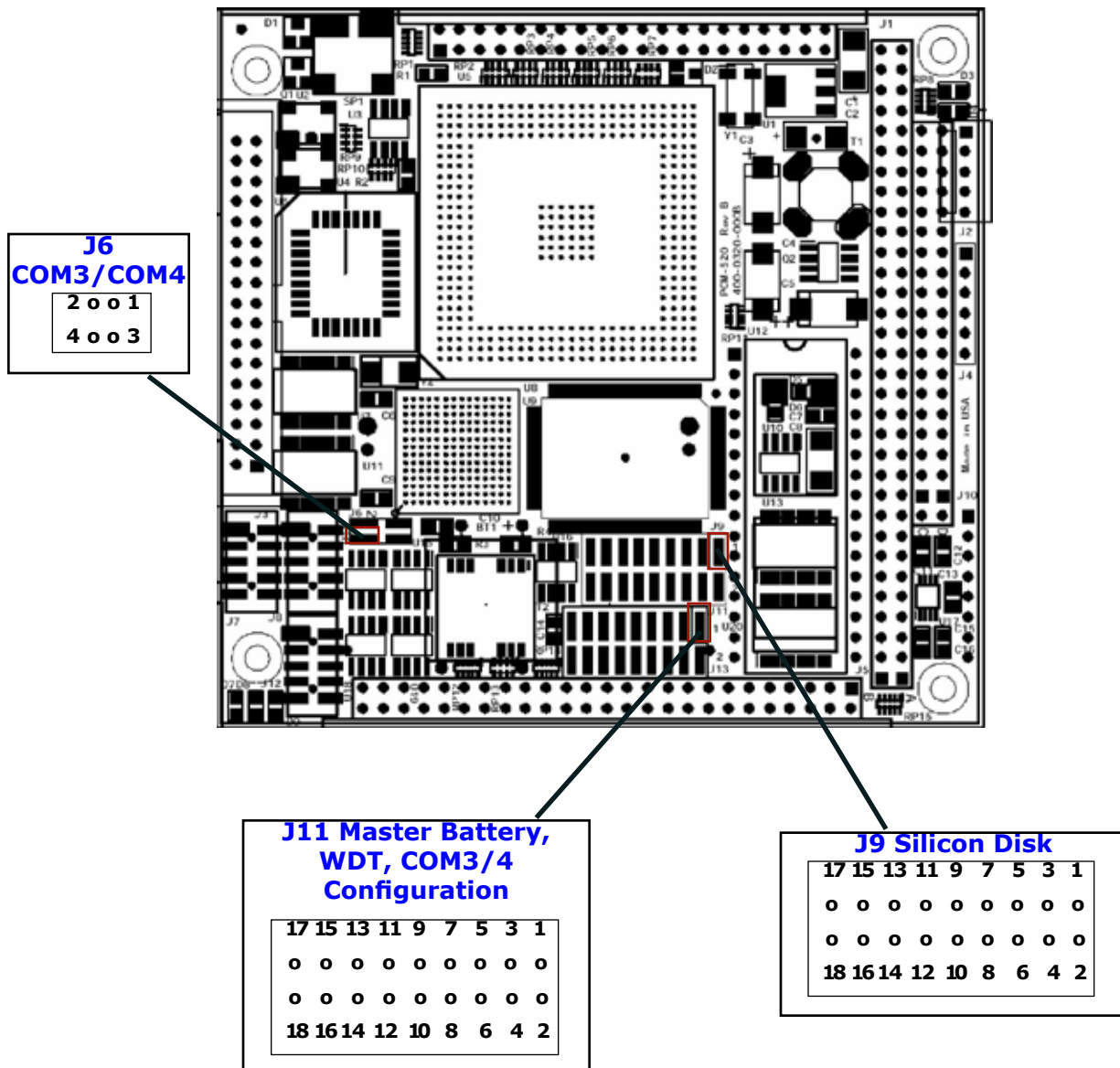

NOTE: The reference line to each component part has been drawn to Pin 1, where applicable. Pin 1 is also highlighted with a red square, where applicable.

COM3/COM4 (J6, J11)

Refer to pages 9 and 10 for more detailed information

COM3:

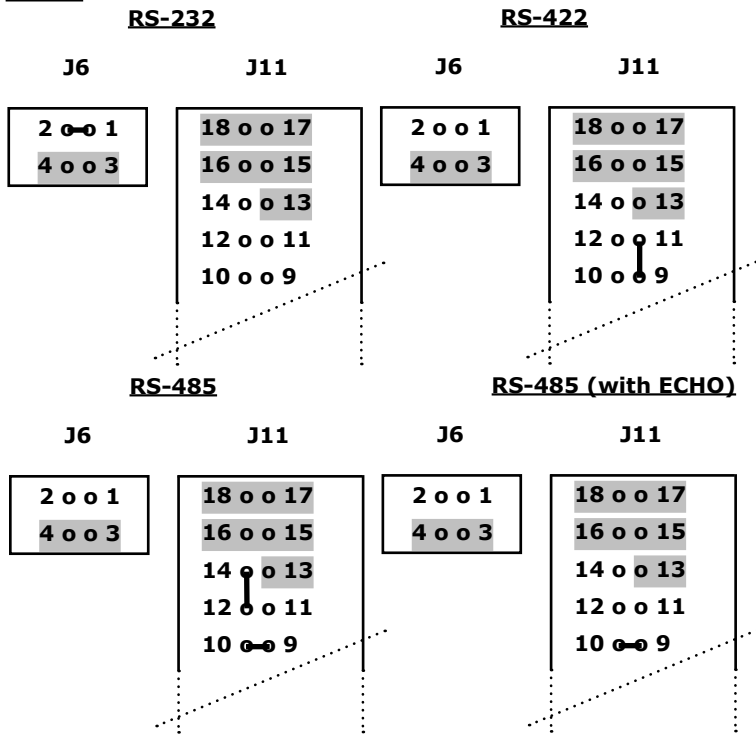

COM4:

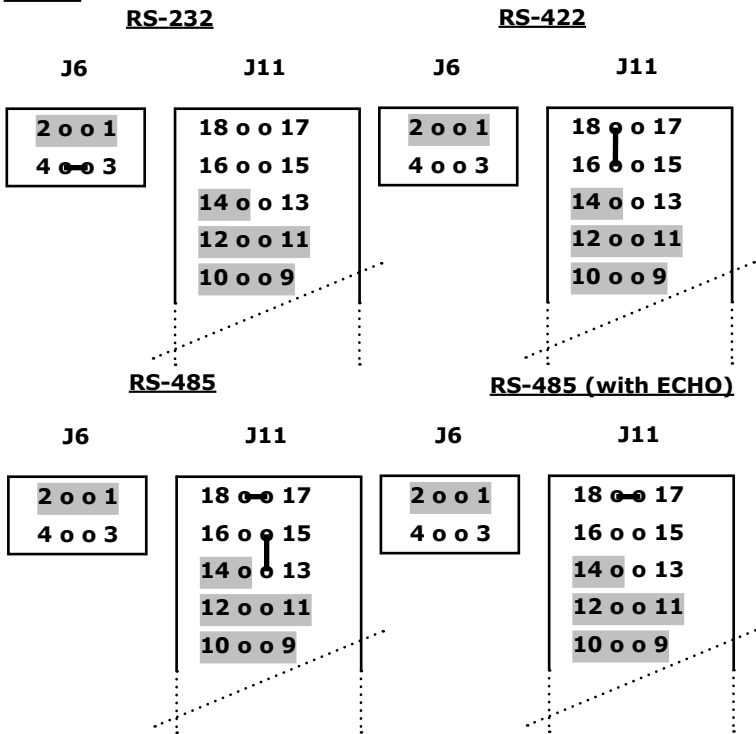

Watchdog Timer and Master Battery (J11)

Refer to pages 11 and 12 for more detailed information

Watchdog Timer (J11)

	3-4	5-6	7-8
DISABLE	OFF	ON	OFF
1.5 SECOND	ON	OFF	OFF
200 SECOND	OFF	OFF	ON

Software ENABLE = PORT 1EEH, BIT 0.

Software watchdog timer PET = PORT 1EFH, write any value.

Master Battery Enable (J11)

	1-2
ENABLE	ON
DISABLE	OFF

Silicon Disk (J9)

Refer to page 7 for more detailed information

DiskOnChip® (DOC)

	17-18	15-16	13-14	11-12	9-10	7-8	5-6	3-4	1-2
C800:0	OFF	ON		ON	ON	ON	ON	ON	ON
CC00:0	OFF	ON		ON	ON	OFF	ON	ON	ON
D000:0	OFF	ON		ON	OFF	ON	ON	ON	ON
D400:0	OFF	ON		ON	OFF	OFF	ON	ON	ON
D800:0	OFF	ON		OFF	ON	ON	ON	ON	ON
DC00:0	OFF	ON		OFF	ON	OFF	ON	ON	ON
E000:0	OFF	ON		OFF	OFF	ON	ON	ON	ON
E400:0	OFF	ON		OFF	OFF	OFF	ON	ON	ON

EPROM

16K window	17-18	15-16	13-14	11-12	9-10	7-8	5-6	3-4	1-2
C800:0	OFF	ON		ON	ON	ON	OFF	ON	ON
CC00:0	OFF	ON		ON	ON	OFF	OFF	ON	ON
D000:0	OFF	ON		ON	OFF	ON	OFF	ON	ON
D400:0	OFF	ON		ON	OFF	OFF	OFF	ON	ON
D800:0	OFF	ON		OFF	ON	ON	OFF	ON	ON
DC00:0	OFF	ON		OFF	ON	OFF	OFF	ON	ON
E000:0	OFF	ON		OFF	OFF	ON	OFF	ON	ON
E400:0	OFF	ON		OFF	OFF	OFF	OFF	ON	ON

32K window	17-18	15-16	13-14	11-12	9-10	7-8	5-6	3-4	1-2
C800:0	ON	OFF		ON	ON	OFF	OFF	ON	OFF
D000:0	ON	OFF		ON	OFF	OFF	OFF	ON	OFF
D800:0	ON	OFF		OFF	ON	OFF	OFF	ON	OFF
E000:0	ON	OFF		OFF	OFF	OFF	OFF	ON	OFF

64K window	17-18	15-16	13-14	11-12	9-10	7-8	5-6	3-4	1-2
D000:0	ON	OFF		X	X	OFF	OFF	OFF	ON

SRAM

32K window	17-18	15-16	13-14	11-12	9-10	7-8	5-6	3-4	1-2
C800:0	ON	OFF		ON	ON	OFF	OFF	ON	OFF
D000:0	ON	OFF		ON	OFF	OFF	OFF	ON	OFF
D800:0	ON	OFF		OFF	ON	OFF	OFF	ON	OFF
E000:0	ON	OFF		OFF	OFF	OFF	OFF	ON	OFF

64K window	17-18	15-16	13-14	11-12	9-10	7-8	5-6	3-4	1-2
D000:0	ON	OFF		X	X	OFF	OFF	OFF	ON

Specifications

Electrical

PCM-SC520 CPU Clock	:133 MHz
PC/104 Interface	:16-bit, stackthrough
Serial Interface	:4 Serial COM channels
Ethernet data rate	:10/100 Fast Ethernet
LPT Interface	:Bi-directional Centronics
IDE Interface	:16-bit, supports 2 drives
Floppy Disk Interface	:Supports either one or two 360K/720K/1.2 MB/1.44 MB drives
Power Requirements	:VCC +5V ±5% @ 900 mA (typ), PCM-520-133 with 32 MB DRAM

System Memory

Addressing	:256 MB
Capacity	:32, 64, 128, or 256 MB of SODIMM SDRAM

Solid State Disk

Capacity	:One 32-pin socket support up to 1GB DiskOnChip One Type I & II CompactFlash socket for up to 2 GB CF
-----------------	--

Mechanical

Dimensions	:3.6 in x 3.8 in (90 mm x 96 mm)
Weight	:4.55 oz. (129.04 grams) <i>approximate weight</i>

Connectors

Serial, Parallel, Mouse and Keyboard	:50-pin, 0.100"
Floppy	:34-pin, 0.100"
IDE	:40-pin, 0.100"
PC/104 Bus	:64-pin, 0.100" 40-pin, 0.100"
COM3, COM4	:10-pin, 2 mm header
Ethernet	:10-pin, 2 mm
Power	:8-pin in-line Molex

Environmental

Operating Temperature	:-40°C to +85°C
Non-condensing relative Humidity	:5% to 95%
MTBF	:19.35 years

WARRANTY REPAIR INFORMATION

WARRANTY

WinSystems warrants to Customer that for a period of two (2) years from the date of shipment any Products and Software purchased or licensed hereunder which have been developed or manufactured by WinSystems shall be free of any material defects and shall perform substantially in accordance with WinSystems' specifications therefore. With respect to any Products or Software purchased or licensed hereunder which have been developed or manufactured by others, WinSystems shall transfer and assign to Customer any warranty of such manufacturer or developer held by WinSystems, provided that the warranty, if any, may be assigned. Notwithstanding anything herein to the contrary, this warranty granted by WinSystems to the Customer shall be for the sole benefit of the Customer, and may not be assigned, transferred or conveyed to any third party. The sole obligation of WinSystems for any breach of warranty contained herein shall be, at its option, either (i) to repair or replace at its expense any materially defective Products or Software, or (ii) to take back such Products and Software and refund the Customer the purchase price and any license fees paid for the same. Customer shall pay all freight, duty, broker's fees, insurance charges for the return of any Products or Software to WinSystems under this warranty. WinSystems shall pay freight and insurance charges for any repaired or replaced Products or Software thereafter delivered to Customer within the United States. All fees and costs for shipment outside of the United States shall be paid by Customer. The foregoing warranty shall not apply to any Products of Software which have been subject to abuse, misuse, vandalism, accidents, alteration, neglect, unauthorized repair or improper installations.

THERE ARE NO WARRANTIES BY WINSYSTEMS EXCEPT AS STATED HEREIN, THERE ARE NO OTHER WARRANTIES EXPRESS OR IMPLIED INCLUDING, BUT NOT LIMITED TO, THE IMPLIED WARRANTIES OF MERCHANTABILITY AND FITNESS FOR A PARTICULAR PURPOSE, IN NO EVENT SHALL WINSYSTEMS BE LIABLE FOR CONSEQUENTIAL, INCIDENTAL OR SPECIAL DAMAGES INCLUDING, BUT NOT LIMITED TO, DAMAGES FOR LOSS OF DATA, PROFITS OR GOODWILL. WINSYSTEMS' MAXIMUM LIABILITY FOR ANY BREACH OF THIS AGREEMENT OR OTHER CLAIM RELATED TO ANY PRODUCTS, SOFTWARE, OR THE SUBJECT MATTER HEREOF, SHALL NOT EXCEED THE PURCHASE PRICE OR LICENSE FEE PAID BY CUSTOMER TO WINSYSTEMS FOR THE PRODUCTS OR SOFTWARE OR PORTION THEREOF TO WHICH SUCH BREACH OR CLAIM PERTAINS.

WARRANTY SERVICE

1. To obtain service under this warranty, obtain a return authorization number. In the United States, contact the WinSystems' Service Center for a return authorization number. Outside the United States, contact your local sales agent for a return authorization number.
2. You must send the product postage prepaid and insured. You must enclose the products in an anti-static bag to protect from damage by static electricity. WinSystems is not responsible for damage to the product due to static electricity.