

OPERATIONS MANUAL PPM-USB2

WinSystems reserves the right to make changes in the circuitry
and specifications at any time without notice.

©Copyright 2004 by WinSystems. All Rights Reserved.

REVISION HISTORY

P/N 403-0317-000

ECO Number	Date Code	Rev Level
ORIGINATED	040914	A

TABLE OF CONTENTS

Section	Paragraph Title	Page
	Visual Index- Quick Reference	i
1	General Information	1-1
1.1	Features	1-1
1.2	General Description	1-1
1.3	Specifications	1-2
2	PPM-USB2 Technical Reference	2-1
2.1	Introduction	2-1
2.2	USB 2.0 Host Controller	2-1
2.3	USB 2.0 TYPE A Interface	2-2
2.4	PC/104 Bus Slot Selection	2-3
2.5	+3.3 Volt/+5 Volt Selection	2-4
2.6	USBVcc Supplemental Voltage	2-5
2.7	Shared Interrupt Selection	2-6
2.8	PC/104 Bus Interface	2-7
2.9	PC/104- <i>Plus</i> Bus Interface	2-8
2.10	Connector/Jumper Summary	2-9
	Warranty and Repair Information	

Visual Index – Quick Reference

For the convenience of the user, a copy of the Visual Index has been provided with direct links to connector and jumper configuration data.

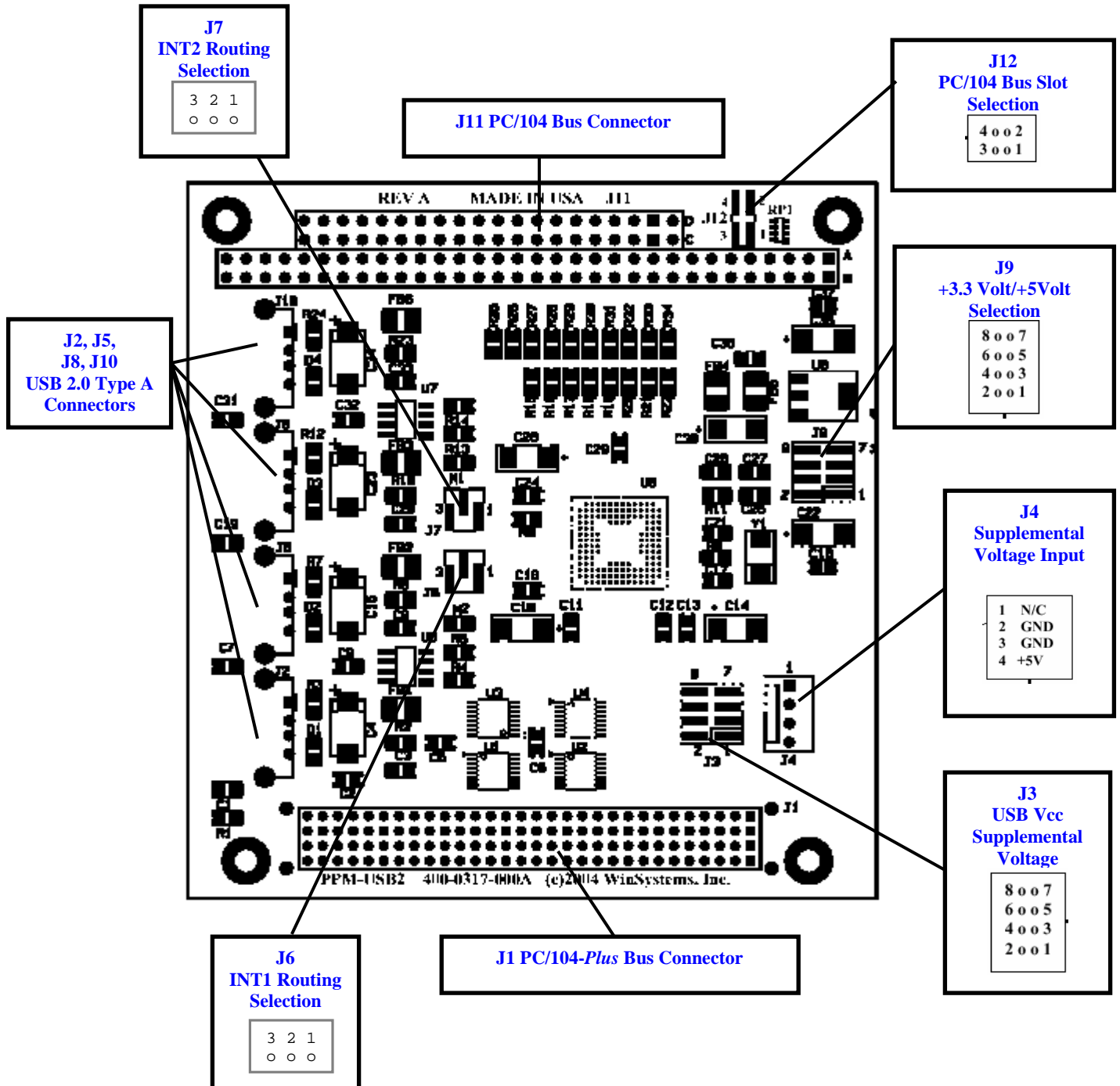

1 General Information

1.1 Features

- USB 2.0 supported on PC/104-Plus module which is 40 times greater Speed than USB 1.1.
- NEC uPD720101 host controller supports simultaneous operation of multiple high performance devices.
- OHCI host and EHCI Host Compliant Cores that are USB 2.0 (480 Mbps) and USB 1.1/USB 1.0 (12 Mbps Compliant)
- Root hub and four downstream facing ports on-board all downstream ports handle low-speed (1.5 Mbps), full-speed (12 Mbps), and High-speed (480 Mbps) transactions.
- Supports hot insertion/removal
- Each port with over-current and inrush protection
- Power connector for supplemental +5V if required
- LED on each port for visual status
- PC/104-Plus compliant board
- Onboard 3.3V regulator
- Supports 5V or 3.3V PC/104-Plus Bus
- Low power
- Single 5V supply
- Operates from -40° to +85° Celsius

1.2 General Description

The PPM-USB2 is a high-speed, 4-port PC/104-Plus Universal Serial Bus (USB 2.0) compliant module. This add-on module is up to 40 times faster than USB 1.x implementations and supports signaling up to 480 Megabits per second (Mbps). It is based upon the NEC uPD720101 USB 2.0 host controller that is supported by a wide range of operating systems including Windows and Linux.

1.3 Specifications

1.3.1 Electrical

Data rate: 1.5/12/480 megabits per second

Power Requirements: $V_{cc} = +5V \pm 5\%$ @ 125mA typical (not including USB)

1.3.2 Mechanical

Dimensions: 3.6" x 3.8" (90mm x 96mm)

Weight: 3.5 oz.

Connectors: USB: Four, USB 2.0 Type A

+5V Power: 4-pin, right angle Molex

PC/104-Plus: 120-pin (4 x 30; 2mm) stack-through with shrouded header

PC/104: 16-bit stack-through (feed through only)

1.3.3 Environmental

Operating Temperature: -40° to +85° C

Non condensing humidity: 5% to 95%

2 PPM-USB2 Technical Reference

2.1 Introduction

This section of the manual is intended to provide the necessary information regarding configuration and usage of the PPM-USB2 board. WinSystems maintains a Technical Support Group to help answer questions regarding usage, or programming of the board. For answers to questions not adequately addressed in this manual, contact Technical Support at (817) 274-7553 between 8AM and 5PM Central Time.

2.2 USB 2.0 Host Controller

The PPM-USB2 module uses the NEC uPD720101 USB 2.0 Host Controller. It complies with the Universal Serial Bus Specification revision 2.0 and Open Host Controller Interface (OHCI) Specification for full-/low-speed signaling and Intel's Enhanced Host Controller Interface (EHCI) Specification for high-speed signaling. The controller also provides a direct Peripheral Component Interconnect (PCI) to the PC/104-*Plus* bus.

The 720101 architecture is optimized to deliver both high-performance and PCI bus efficiency with the lowest power and smallest size. There are two OHCI controller cores for full-/low-speed signaling and one EHCI host controller for high-speed signaling. The OHCI and EHCI controller cores share four downstream facing ports on a root hub. All downstream facing ports can handle high-speed (480 Mbps), full-speed (12 Mbps), and low-speed (1.5 Mbps) transactions.

Port Protection – Each port has over-current and in rush protection provided by two National Semiconductor LM3526 power switches. One LM3526 protects Ports 1 and 2, while the other protects Ports 3 and 4.

2.3 USB 2.0 Type A Interface

The four TYPE A USB connectors are located at J2, J5, J8 & J10, as seen below.

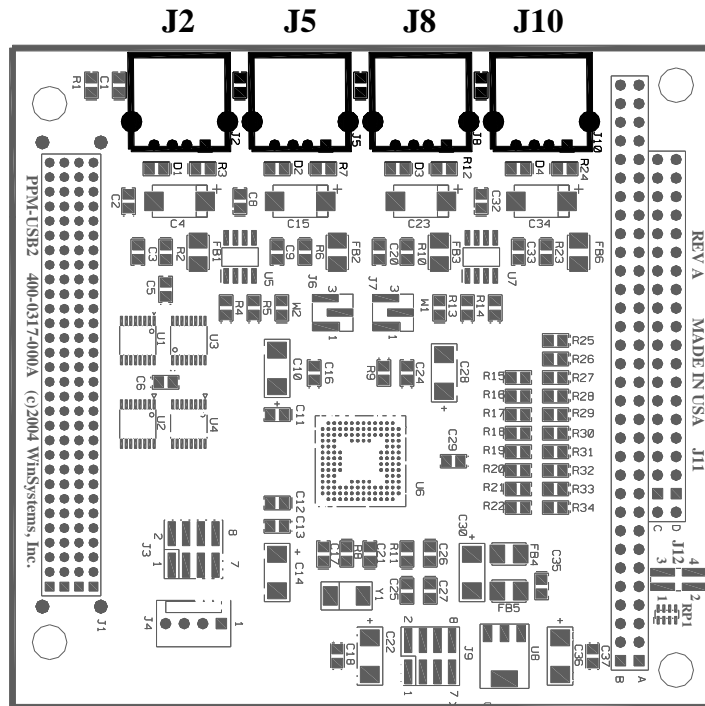

2.4 PC/104 Bus Slot Selection

J12 is used to select the “slot” number of the PCI connection for the board. Each PC/104-*Plus* board installed in a system must have a unique “slot” assignment and must not conflict with any PCI “slot” assignments on the CPU card. The jumper settings for J12 are shown here:

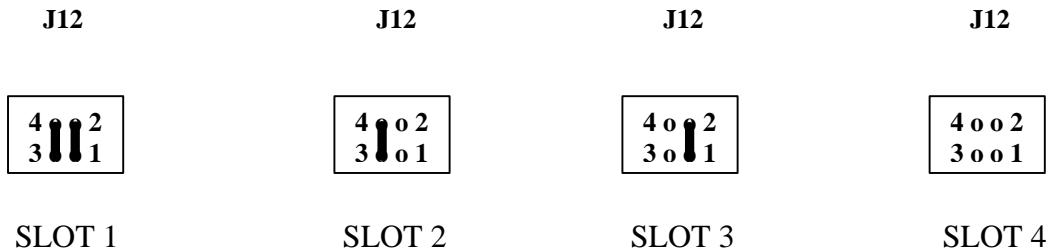
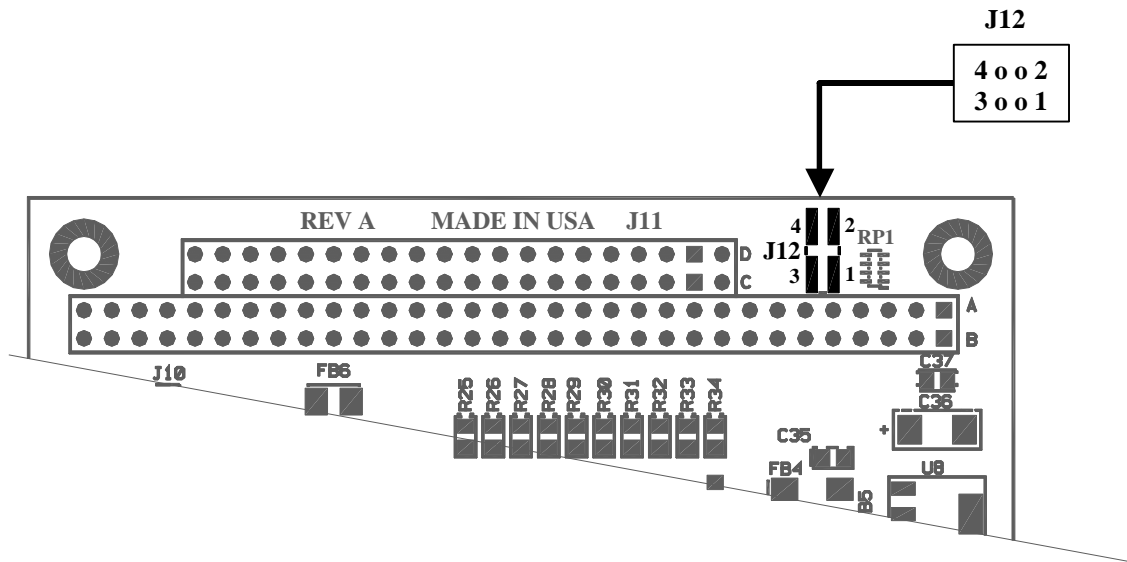

2.5 +3.3 Volt/+5 Volt Selection

Note: Incorrectly configuring externally supplied voltage sources may cause damage to components and/or printed circuits. Please verify jumper selections before applying power.

J9 routes the voltage sources supplied from the PC/104-Plus bus to the on-board Vcc circuit. Refer to the jumpering options shown below to route the appropriate voltage. When the supplied voltage is +3.3 volts, connecting J9 pins 1-2 and 3-4 routes +3.3 volts directly to the PPM-USB2 Vcc circuit. When +5 volts are supplied to the PC/104-Plus bus connector, jumpering pins 5-6 and 7-8 routes +5 volts to an on-board DC regulator, which converts the +5 Volt source to +3.3 volts for Vcc.

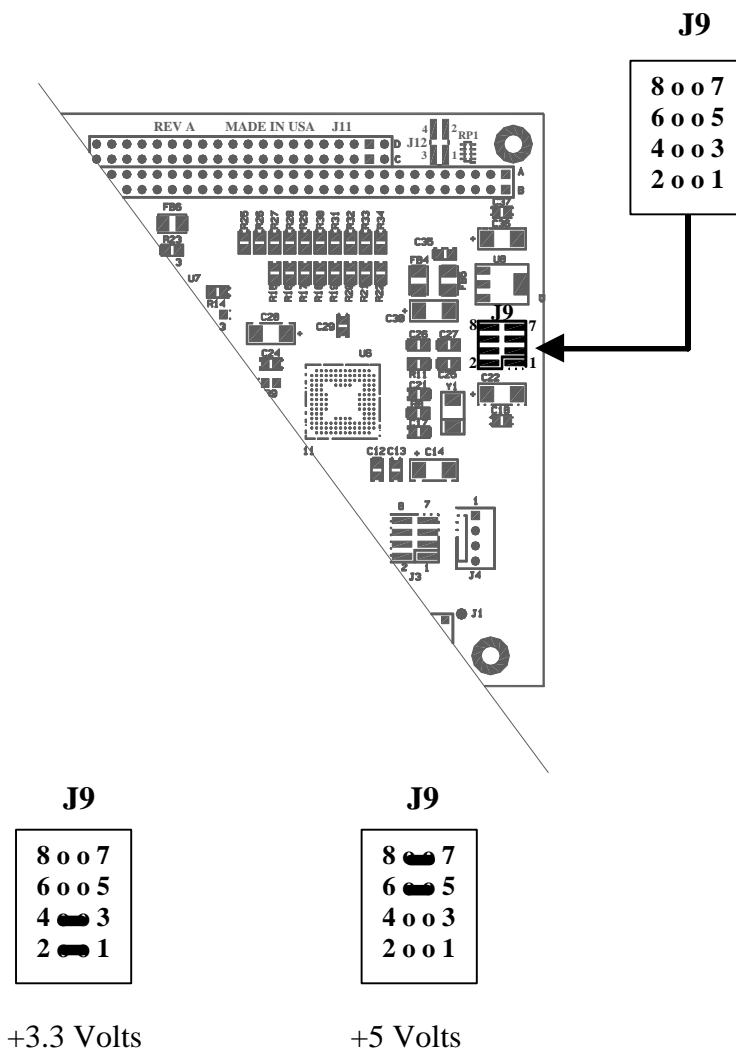

2.6 USB VCC Supplemental Voltage

Note: Incorrectly configuring externally supplied voltage sources may cause damage to components and/or printed circuits. Please verify jumper selections before applying power.

Each USB port can supply up to 500mA. If the total USB current demand exceeds the available current supplied by the PC/104 & PC/104-Plus connector, an external power source may be required.

J3 selects the source for USB VCC +5 volts. Jumpering J3, pins 1-2 and 3-4 routes the external voltage source connected to J4 (see pin definitions below) to the four USB ports. Jumpering pins 5-6 and 7-8 connects +5 volts, supplied through the PC/104-Plus (PCI) bus connector.

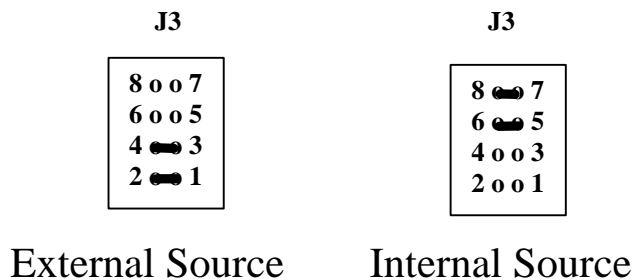
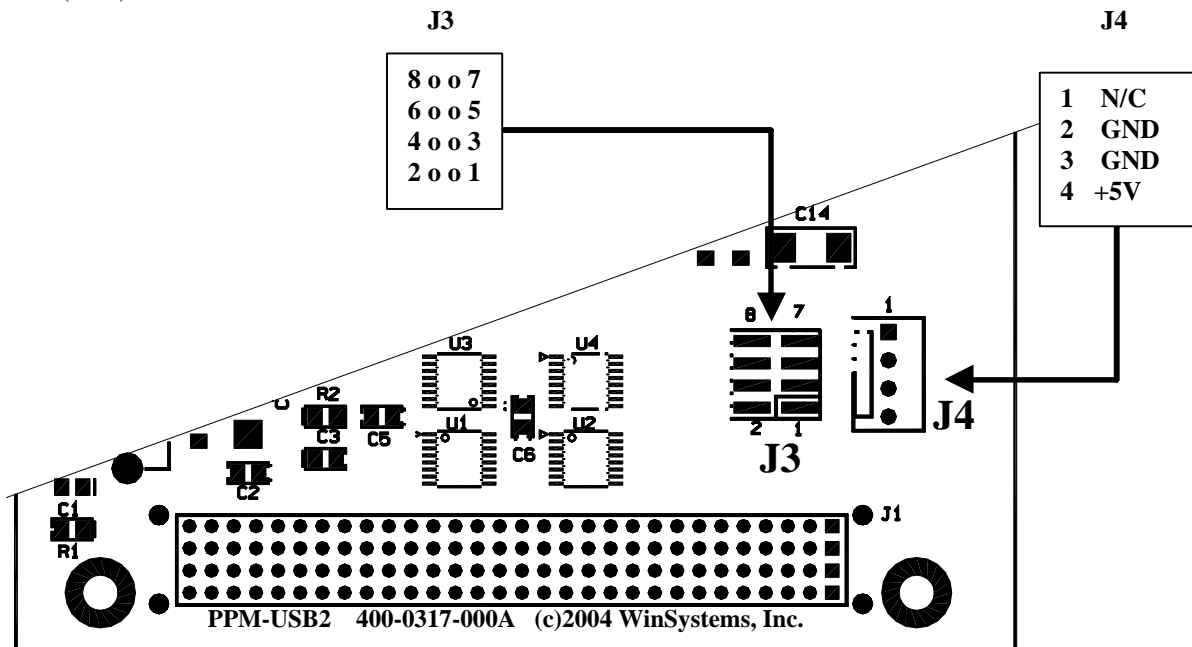

2.7 Shared Interrupt Selection

J6 and J7 are interrupt routing jumpers for the USB controller. It is possible to route the three individual interrupts INT0, INT1, and INT2 to a single interrupt, or all three interrupts may be routed individually from the USB controller to the PC/104-Plus bus.

To configure for one common interrupt for all three controllers, J6 would be jumpered 2-3, and J7 as 2-3. To configure as three individual controllers, J6 would be jumpered 1-2, and J7 as 1-2.

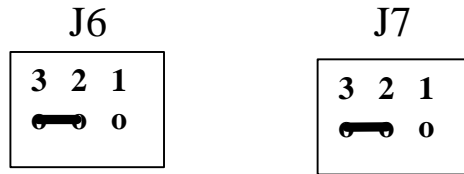

Common Interrupts

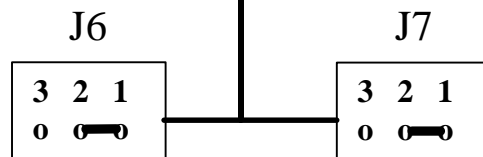
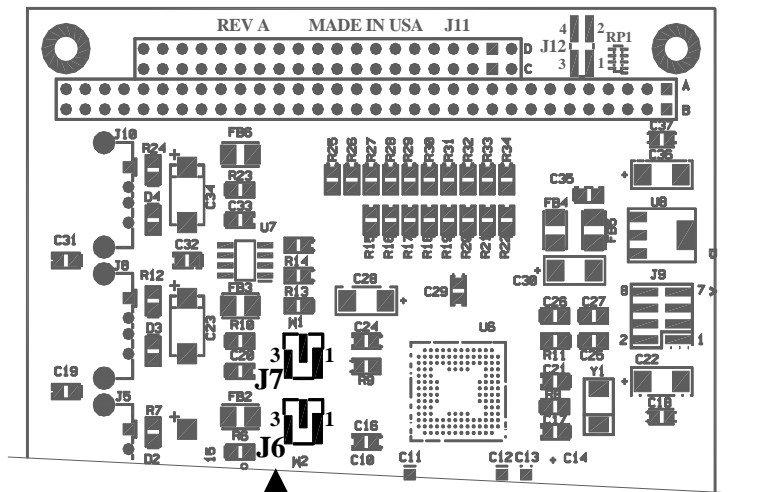

Individual Interrupts

2.8 PC/104 Bus Interface

The PPM-USB2 connects to the processor through the PC/104 bus connector at J11. The pin definitions for the 8-bit and 16-bit portions are shown here.

GND	B1 ○ ○ A1	IOCHK*			
RESET	B2 ○ ○ A2	SD7			
+5V	B3 ○ ○ A3	SD6			
IRQ9	B4 ○ ○ A4	SD5			
-5V	B5 ○ ○ A5	SD4			
DRQ2	B6 ○ ○ A6	SD3			
-12V	B7 ○ ○ A7	SD2			
SRDY*	B8 ○ ○ A8	SD1			
+12V	B9 ○ ○ A9	SD0			
GND	B10 ○ ○ A10	IOCHRDY			
MEMW*	B11 ○ ○ A11	AEN			
MEMR*	B12 ○ ○ A12	SA19			
IOW*	B13 ○ ○ A13	SA18	GND	C0 ○ ○ D0	GND
IOR*	B14 ○ ○ A14	SA17	SBHE*	C1 ○ ○ D1	MEMCS16*
DACK3*	B15 ○ ○ A15	SA16	LA23	C2 ○ ○ D2	IOCS16*
DRQ3	B16 ○ ○ A16	SA15	LA22	C3 ○ ○ D3	IRQ10
DACK1*	B17 ○ ○ A17	SA14	LA21	C4 ○ ○ D4	IRQ11
DRQ1	B18 ○ ○ A18	SA13	LA20	C5 ○ ○ D5	IRQ12
REFRESH*	B19 ○ ○ A19	SA12	LA19	C6 ○ ○ D6	IRQ15
SYSCLK	B20 ○ ○ A20	SA11	LA18	C7 ○ ○ D7	IRQ14
IRQ7	B21 ○ ○ A21	SA10	LA17	C8 ○ ○ D8	DACK0*
IRQ6	B22 ○ ○ A22	SA9	MEMR*	C9 ○ ○ D9	DRQ0
IRQ5	B23 ○ ○ A23	SA8	MEMW*	C10 ○ ○ D10	DACK5*
IRQ4	B24 ○ ○ A24	SA7	SD8	C11 ○ ○ D11	DRQ5
IRQ3	B25 ○ ○ A25	SA6	SD9	C12 ○ ○ D12	DACK6*
DACK2*	B26 ○ ○ A26	SA5	SD10	C13 ○ ○ D13	DRQ6
TC	B27 ○ ○ A27	SA4	SD11	C14 ○ ○ D14	DACK7*
BALE	B28 ○ ○ A28	SA3	SD12	C15 ○ ○ D15	DRQ7
+5V	B29 ○ ○ A29	SA2	SD13	C16 ○ ○ D16	+5V
OSC	B30 ○ ○ A30	SA1	SD14	C17 ○ ○ D17	MASTER*
GND	B31 ○ ○ A31	SA0	SD15	C18 ○ ○ D18	GND
GND	B32 ○ ○ A32	GND	KEY	C19 ○ ○ D19	GND

J11 PC/104 BUS CONNECTOR

2.9 PC/104-Plus Bus Interface

Pin	A	B	C	D
1	GND	RESERVED	+5	AD00
2	VI/O	AD02	AD01	+5V
3	AD05	GND	AD04	AD03
4	C/BE0#	AD07	GND	AD06
5	GND	AD09	AD08	GND
6	AD11	VI/O	AD10	M66EN
7	AD14	AD13	GND	AD12
8	+3.3V	C/BE1#	AD15	+3.3V
9	SERR#	GND	RESERVED	PAR
10	GND	PERR#	+3.3V	RESERVED
11	STOP#	+3.3V	LOCK#	GND
12	+3.3V	TRDY#	GND	DEVSEL#
13	FRAME#	GND	IRDY#	+3.3V
14	GND	AD16	+3.3V	C/BE2#
15	AD18	+3.3V	AD17	GND
16	AD21	AD20	GND	AD19
17	+3.3V	AD23	AD22	+3.3V
18	IDSEL0	GND	IDSEL1	IDSEL2
19	AD24	C/BE3#	VI/O	IDSEL3
20	GND	AD26	AD25	GND
21	AD29	+5V	AD28	AD27
22	+5V	AD30	GND	AD31
23	REQ0#	GND	REQ1#	VI/O
24	GND	REQ2#	+5V	GNT0#
25	GNT1#	VI/O	GNT2#	GND
26	+5V	CLK0	GND	CLK1
27	CLK2	+5V	CLK3	GND
28	GND	INTD#	+5V	RST#
29	+12V	INTA#	INTB#	INTC#
30	-12V	REQ3#	GNT3#	GND

J1 - PC/104-PLUS BUS CONNECTOR

NOTE: 1. The shaded area denotes power or ground signals.

2.10 Connector/Jumper Summary

Reference		Page
J1	PC/104- <i>Plus</i> Bus Connector	2-8
J2, J5, J8, J10	USB 2.0 Type A	2-2
J3	USB Vcc Supplemental Voltage	2-5
J4	Supplemental Voltage Input	2-5
J6	INT1 Routing Selection	2-6
J7	INT2 Routing Selection	2-6
J9	3.3V/5V Selection	2-4
J11	PC/104 Bus Connector	2-7
J12	Board/Slot Selection	2-3

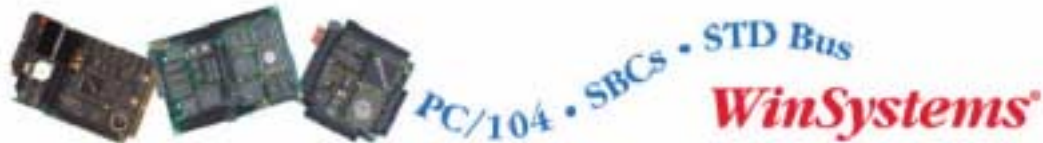

Telephone: 817-274-7553 . . Fax: 817-548-1358
<http://www.winsystems.com> . . E-mail: info@winsystems.com

WARRANTY

WinSystems warrants that for a period of two (2) years from the date of shipment any Products and Software purchased or licensed hereunder which have been developed or manufactured by WinSystems shall be free of any material defects and shall perform substantially in accordance with WinSystems' specifications therefore. With respect to any Products or Software purchased or licensed hereunder which have been developed or manufactured by others, WinSystems shall transfer and assign to Customer any warranty of such manufacturer or developer held by WinSystems, provided that the warranty, if any, may be assigned. The sole obligation of WinSystems for any breach of warranty contained herein shall be, at its option, either (i) to repair or replace at its expense any materially defective Products or Software, or (ii) to take back such Products and Software and refund the Customer the purchase price and any license fees paid for the same. Customer shall pay all freight, duty, broker's fees, insurance changes and other fees and charges for the return of any Products or Software to WinSystems under this warranty. WinSystems shall pay freight and insurance charges for any repaired or replaced Products or Software thereafter delivered to Customer within the United States. All fees and costs for shipment outside of the United States shall be paid by Customer. The foregoing warranty shall not apply to any Products or Software which have been subject to abuse, misuse, vandalism, accidents, alteration, neglect, unauthorized repair or improper installations.

THERE ARE NO WARRANTIES BY WINSYSTEMS EXCEPT AS STATED HEREIN. THERE ARE NO OTHER WARRANTIES EXPRESS OR IMPLIED INCLUDING, BUT NOT LIMITED TO, THE IMPLIED WARRANTIES OF MERCHANTABILITY AND FITNESS FOR A PARTICULAR PURPOSE, IN NO EVENT SHALL WINSYSTEMS BE LIABLE FOR CONSEQUENTIAL, INCIDENTAL, OR SPECIAL DAMAGES INCLUDING, BUT NOT LIMITED TO, DAMAGES FOR LOSS OF DATA, PROFITS OR GOODWILL. WINSYSTEMS' MAXIMUM LIABILITY FOR ANY BREACH OF THIS AGREEMENT OR OTHER CLAIM RELATED TO ANY PRODUCTS, SOFTWARE, OR THE SUBJECT MATTER HEREOF, SHALL NOT EXCEED THE PURCHASE PRICE OR LICENSE FEE PAID BY CUSTOMER TO WINSYSTEMS FOR THE PRODUCTS OR SOFTWARE OR PORTION THEREOF TO WHICH SUCH BREACH OR CLAIM PERTAINS.

WARRANTY SERVICE

All products returned to WinSystems must be assigned a Return Material Authorization (RMA) number. To obtain this number, please call or FAX WinSystems' factory in Arlington, Texas and provide the following information:

1. Description and quantity of the product(s) to be returned including its serial number.
2. Reason for the return.
3. Invoice number and date of purchase (if available), and original purchase order number.
4. Name, address, telephone and FAX number of the person making the request.
5. Do not debit WinSystems for the repair. WinSystems does not authorize debits.

After the RMA number is issued, please return the products promptly. Make sure the RMA number is visible on the outside of the shipping package.

The customer must send the product freight prepaid and insured. The product must be enclosed in an anti-static bag to protect it from damage caused by static electricity. Each bag must be completely sealed. Packing material must separate each unit returned and placed as a cushion between the unit(s) and the sides and top of the shipping container. WinSystems is not responsible for any damage to the product due to inadequate packaging or static electricity.